

INSTRUCTION  
MANUAL

# DIRIS A-40

PMD - Multifunction meter

EN



[www.socomec.com/  
en/documentation/  
diris-a40](http://www.socomec.com/en/documentation/diris-a40)

<b>1. DOCUMENTATION</b> .....	3
<b>2. HAZARDS AND WARNINGS</b> .....	4
2.1. Risk of electrocution, burns or explosion .....	4
2.2. Risk of damaging the device .....	4
2.3. Responsibility .....	5
<b>3. PRELIMINARY OPERATIONS</b> .....	6
<b>4. INTRODUCTION</b> .....	7
4.1. DIRIS A-40 presentation .....	7
4.1.1. Range .....	7
4.1.2. Principle .....	8
4.1.3. Functions .....	9
4.1.4. Dimensions .....	11
4.1.5. Front panel .....	11
4.2. Presentation of associated current sensors .....	13
4.2.1. TE solid-core current sensors .....	14
4.2.2. TR / iTR split-core current sensors .....	16
4.2.3. TF flexible current sensors .....	17
4.2.4. Adapters for 5A sensors .....	18
<b>5. INSTALLATION</b> .....	19
5.1. Recommendations and safety .....	19
5.2. Installing DIRIS A-40 .....	19
5.3. Installing TE solid-core sensors .....	20
5.3.1. Mounting accessories .....	20
5.3.2. DIN rail mounting .....	20
5.3.3. Plate mounting .....	22
5.3.4. Installing on a cable with clamping collar .....	24
5.3.5. Bar mounting .....	25
5.3.6. Sensors assembly .....	26
5.3.7. Sealing accessories for sensors .....	26
5.4. Installing TR split-core sensors .....	27
5.4.1. Cable mounting .....	27
5.5. Flexible TF sensors mounting .....	28
5.5.1. Installing the casing .....	28
5.5.2. Cable mounting .....	28
5.5.3. Bar mounting .....	29
5.6. Installing the 5A adapter .....	29
<b>6. CONNECTION</b> .....	30
6.1. DIRIS A-40 connection .....	30
6.2. Connection to the electrical network and to the loads .....	32
6.2.1. Configurable loads based on the network type .....	32
6.2.2. Description of the main network and load combinations .....	32
<b>7. COMMUNICATION</b> .....	34
7.1. Modbus General information .....	34
7.2. RS485 rules .....	34
7.3. Modbus and Profibus communication tables .....	34
<b>8. CONFIGURATION</b> .....	35
8.1. Configuration using Easy Config .....	35
8.1.1. Connection modes .....	35
8.1.2. Using Easy Config .....	37
8.2. Configuration from the display .....	40
8.2.1. Navigation .....	40
8.2.2. Description of the Wizard .....	40
8.2.3. Complete configuration .....	41

8.3. Screen menu structure.....	43
<b>9. USE .....</b>	<b>44</b>
9.1. Browse .....	44
9.2. Shortcuts .....	44
9.3. Favourites .....	44
9.4. Screen display of measurements.....	44
<b>10. ALARMS .....</b>	<b>45</b>
10.1. Alarms upon events .....	45
10.1.1. Electrical parameters.....	45
10.1.2. Voltage and current unbalance (in a three-phase network) .....	45
10.1.3. EN 50160 voltage quality events.....	46
10.1.4. Consumption .....	46
10.1.5. Digital inputs.....	46
10.1.6. Combination of alarms .....	46
10.2. System alarms.....	47
10.2.1. Current/voltage compatibility .....	47
10.2.2. Incorrect direction of rotation (three-phase network).....	47
10.2.3. Faulty current sensor.....	47
10.3. Setting up alarms .....	47
10.3.1. ALARM LED on front.....	47
10.3.2. Activation of an output .....	47
10.3.3. Activation of an input.....	48
10.3.4. RS485 Modbus .....	48
10.3.5. Screen and WEBVIEW .....	48
<b>11. WEB SERVER .....</b>	<b>49</b>
<b>12. CHARACTERISTICS.....</b>	<b>50</b>
12.1. DIRIS A-40 characteristics .....	50
12.1.1. Mechanical features.....	50
12.1.2. Electrical specifications .....	50
12.1.3. Measuring characteristics .....	50
12.1.4. Input/output characteristics .....	51
12.1.5. Communication specifications .....	51
12.1.6. Environmental specifications .....	52
12.1.7. Electromagnetic compatibility.....	52
12.1.8. Safety .....	53
12.1.9. Service life.....	53
12.2. TE, TR / ITR and TF sensor characteristics .....	54
<b>13. PERFORMANCE CLASSES .....</b>	<b>56</b>
13.1. Specification of the characteristics .....	56
13.2. Evaluation of the power supply quality.....	57

# 1. DOCUMENTATION

All documentation on the DIRIS A-40 is available on the website at the following address:  
[www.socomec.com/en/documentation/diris-a40](http://www.socomec.com/en/documentation/diris-a40)





## 2. HAZARDS AND WARNINGS

The term "device" used in the paragraphs below refers to the DIRIS A-40.

The assembly, use, servicing and maintenance of this product must only be carried out by trained, qualified professionals.

SOCOMECC shall not be held responsible for failure to comply with the instructions in this manual.

### 2.1. Risk of electrocution, burns or explosion



	Caution: risk of electric shock	Ref. ISO 7000-0434B (2004-01)
	Caution: refer to the accompanying documentation each time this symbol is shown	Ref. ISO 7010-W001 (2011-05)

- Only duly authorised and qualified personnel may work or install/uninstall the device.
- The instructions are valid together with the specific instructions for the device.
- The device is designed only for its intended purpose as set out in the instructions.
- Only accessories authorised or recommended by SOCOMECC may be used in association with the device.
- Before proceeding with installation, maintenance, cleaning, disassembly, connection, or maintenance work, the device and system must be cut off from the mains to avoid electrocution and damaging the system and device.
- This device is not designed to be repaired by the user.
- For any questions related to the disposal of the device, please contact SOCOMECC.

	Do NOT clamp or pull out NON-INSULATED conductors carrying DANGEROUS VOLTAGE which could cause an electric shock, burn or arc flash. Ref. IEC 61010-2-032
---	--

**Failure to comply with the instructions of the device and this safety information can cause bodily injury, electric shock, burns, death or damage to property.**

### 2.2. Risk of damaging the device

	Caution: risk of electric shock	Ref. ISO 7000-0434B (2004-01)
	Caution: refer to the accompanying documentation each time this symbol is shown	Ref. ISO 7010-W001 (2011-05)

To ensure that the device operates correctly, make sure that:

- The device is correctly installed.
- There is a maximum voltage at the voltage measurement input terminals of 520 V AC phase-phase or 300 V AC phase-neutral.
- There is a maximum voltage at the auxiliary power supply input terminals of 400 V AC.
- The network frequency indicated on the device is observed: 50 or 60 Hz.
- Always connect the TE, TR or TF current sensors using the recommended connection cables and observing the maximum prescribed currents.
- When the ambient temperature exceeds +50°C, the minimum temperature rating of the copper cable to be connected to terminal must be +85°C.

**Failure to respect these precautions could cause damage to the device.**

## 2.3. Responsibility

- Assembly, connection and use must be carried out in accordance with the installation standards currently in force.
- The device must be installed in accordance with the rules given in this manual.
- Failure to observe the rules for installing this unit may compromise the device's intrinsic protection.
- The device must be positioned within an installation which complies with the standards currently in force.
- Any cable which needs to be replaced may only be replaced with a cable having the correct rating.
- Despite constantly striving for quality in preparing this manual, errors or omissions are always a possibility and are not the responsibility of SOCOMEC.

### 3. PRELIMINARY OPERATIONS

To ensure the safety of staff and the equipment, it is vital to read and absorb the contents of these instructions thoroughly before commissioning.

Check the following points as soon as you receive the package containing the device:

- The packaging is in good condition
- The device has not been damaged during transit,
- The device part number conforms to your order
- The package includes:
  - 1 device equipped with removable terminals
  - 1 line resistor (ref. 4899 0019)
  - 1 Quick Start guide

## 4. INTRODUCTION

### 4.1. DIRIS A-40 presentation

The DIRIS A-40 is a compact PMD\* with a 96\*96 format. It is designed for measuring, monitoring and reporting electrical energy. The DIRIS A-40 offers a range of functions for measuring voltage, current, power, energy and quality. It allows the analysis of a single-phase or three-phase load.

The DIRIS A-40 has 3 digital inputs (pulse metering, status checking) and 2 outputs (Alarm or pulses). The standard version of the device has RS485 Modbus communication. Depending on the models, Ethernet or Profibus communication may also be provided. The Ethernet model also has a built-in web server.

The connection mode for the current sensors allows quick, easy installation. Their automatic identification (type and rating) by the DIRIS A-40 significantly reduces the risk of errors during installation. In addition, this approach, based on combining the sensor with the DIRIS A-40, means the overall accuracy of the DIRIS A-40 + Current sensor measurement chain can be guaranteed for all values measured.

The product is configured from the display or via the Easy Config software. The measurements can be accessed via the WEBVIEW web server, available on the DIRIS G-30, G-40, G-50 and G-60 communication gateways, enabling real-time monitoring of the electrical values and reporting of the energy data. The data can also be accessed via the N'VIEW energy management software.

\*PMD: Performance Measuring and Monitoring Device in accordance with IEC 61557-12.

#### 4.1.1. Range

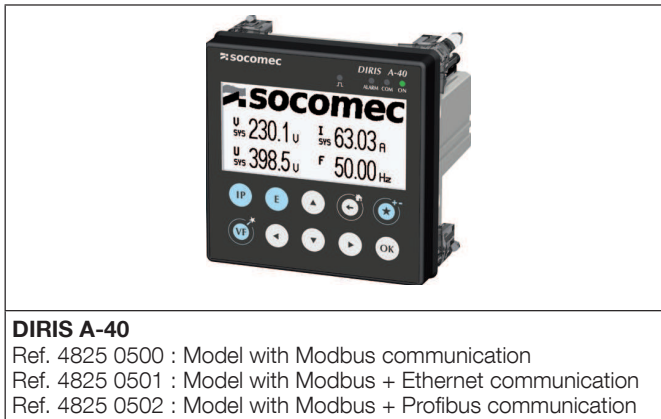

## 4.1.2. Principle



Current sensors  
TE, TR or TF



### 4.1.3. Functions

The DIRIS A-40 boasts numerous functions, including:

- General measurements
  - Electrical values, voltage, current, frequency
  - Power, power factor, cos phi and tan phi
  - 4 quadrant operation
  - Predictive power
  - Overall accuracy of the DIRIS A-40 + Sensors measurement chain guarantees up to class 0.5 (depending on the current sensor used) in power and active energy in accordance with IEC 61557-12
- Quality
  - Current, phase-to-neutral voltage and phase-to-phase voltage
  - THD, TDD and harmonics up to level 63 for voltage and current
  - Voltage and current crest factor
  - Voltage and current unbalance
  - K-factor
  - EN50160 events (Uswl, Udip, Uint) and current overloads
- Data log
  - Recording of averaged electrical values
  - Recording and timestamping of min/max electrical values
- Metering
  - Active, reactive, apparent energy total and partial
  - Load curves
  - Multi-tariff metering
- Alarm
  - Timestamped alarms with boolean combination
  - Advanced alarms
- Connection to the network
  - 3 current inputs with automatic recognition of the current sensors by quick connection (type RJ12)
  - Control of the connection, detection of the current sensors and auto-configuration of the networks
  - Guaranteed overall accuracy of the DIRIS A-40 + Sensors measurement chain in accordance with IEC 61557-12
- Inputs/outputs
  - 3 logic inputs
  - 2 logic outputs
- Communication
  - RS485 Modbus RTU
  - RS485 Modbus RTU and Profibus
  - RS485 Modbus RTU and Ethernet (Modbus TCP, BACnet)
- Web Server
  - Embedded Web Server for the DIRIS A-40 ethernet (Réf. 4825 0501)

**DIRIS A-40**

Reference	4825 0500	4825 0501	4825 0502
<b>Number of current inputs</b>	3	3	3
<b>Metering</b>			
Total and partial Ea+, Ea-, Er+, Er-, Eap	•	•	•
Multi-tariff (max. 8)	•	•	•
<b>Multi-measurement</b>			
V1, V2, V3, Vn, U12, U23, U31, f			
I1, I2, I3, IN	•	•	•
P, Q, S, PF per phase, $\Sigma P$ , $\Sigma Q$ , $\Sigma S$ , $\Sigma PF$	•	•	•
Predictive power P, Q, S	•	•	•
Phi, cos Phi, tan Phi	•	•	•
<b>Quality</b>			
Voltage unbalance Vnba, Vnb, Unba, Unb	•	•	•
Current unbalance Inba, Inb	•	•	•
THDV1, THDV2, THDV3, THDVn, THDU12, THDU23, THDU31	•	•	•
THDI1, THDI2, THDI3, THDI <sub>n</sub> , THD <sub>Isys</sub> , TDD	•	•	•
Individual harmonics V, U, I (up to level 63)	•	•	•
Crest Factor, k-factor	•	•	•
Overvoltages, Voltage dips, Supply voltage interruptions according to EN 50160	•	•	•
Overcurrents	•	•	•
<b>Alarms</b>			
Thresholds	•	•	•
Digital	•	•	•
Boolean	•	•	•
<b>Inputs/Outputs</b>			
Number	3/2	3/2	3/2
<b>Trends</b>			
Load curves	•	•	•
Energy index		•	
Average values		•	
<b>Web Server</b>			
Power & Energy Monitoring		•	
<b>Communication</b>			
RS485 RTU Modbus	•		
RS485 Modbus RTU and Profibus DPV1			•
RS485 Modbus RTU and Ethernet (Modbus TCP, BACnet)		•	
SNTP, SMTP, FTP		•	

#### 4.1.4. Dimensions



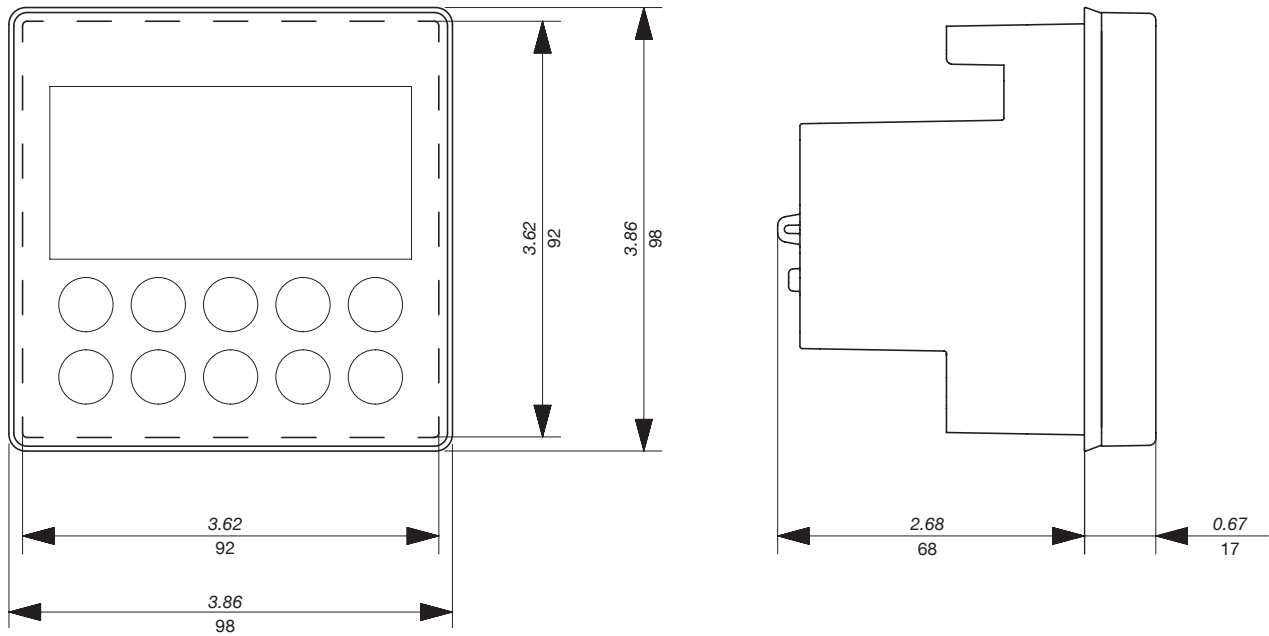

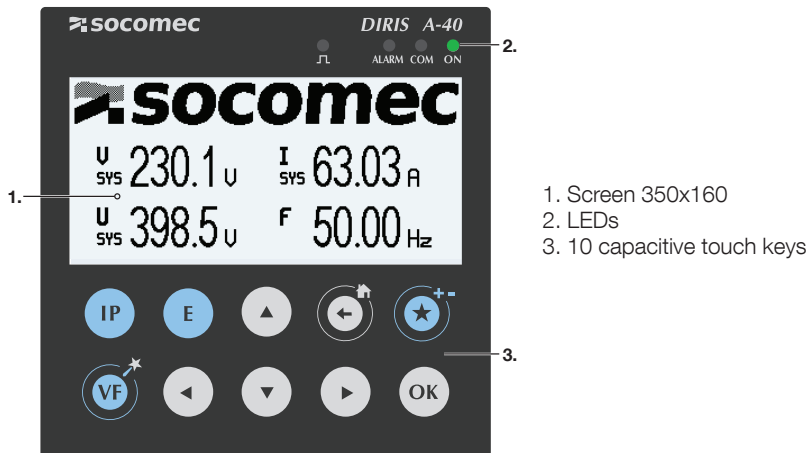

Dimensions: in/mm



#### 4.1.5. Front panel

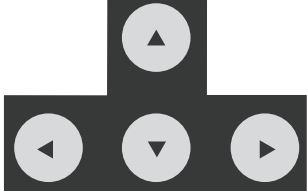

The display consists of a screen and 10 keys:

	<p>Shortcut keys for load measurements: current, active power, reactive power, apparent power, power factor, cos phi</p>
	<p>Shortcut keys for electrical network measurements: phase-to-neutral voltage, phase-to-phase voltage, frequency Shortcut keys for the Wizard by holding down</p>
	<p>Shortcut keys for active, reactive, apparent energy meters (total and partial values)</p>
	<p>Arrow keys for navigation</p>
	<p>Use this to go up a level in the display navigation menus and to return to the main menu by holding down</p>
	<p>Use this to save favourite screens by holding down and then to view them with a short press Use this to remove favourite screens by holding down</p>
	<p>Use this to confirm your navigation or entry selection</p>

LED display:

	<p><b>П</b></p> <ul style="list-style-type: none"> <li>- Flashing: metering of consumption pulses pulse weight: 0.1 Wh</li> </ul> <p><b>/ALARM</b></p> <ul style="list-style-type: none"> <li>- Off: no alarm in progress</li> <li>- Flashing: system alarm in progress</li> <li>- Fixed: alarm in progress or alarm ended and not acknowledged</li> </ul> <p><b>COM</b></p> <ul style="list-style-type: none"> <li>- Off: no communication</li> <li>- Flashing: communication in progress on the RS485 bus</li> </ul> <p><b>ON</b></p> <ul style="list-style-type: none"> <li>- Off: device is off</li> <li>- On: product working OK</li> </ul> <p>NOTE: When the 4 LEDs are flashing: a problem has been detected in the device</p>
---	---

## 4.2. Presentation of associated current sensors

Various types of current sensors are connected to the DIRIS A-40: solid-core (TE), split-core (TR, iTR) or flexible (TF). The variety between these sensors means they can be adapted to any type of new, existing or high-current existing installation. The DIRIS A-40 recognizes the sensor size and type. In addition, combining them means the overall accuracy of the DIRIS A-40 + current sensor measurement chain can be guaranteed over a large measurement range.

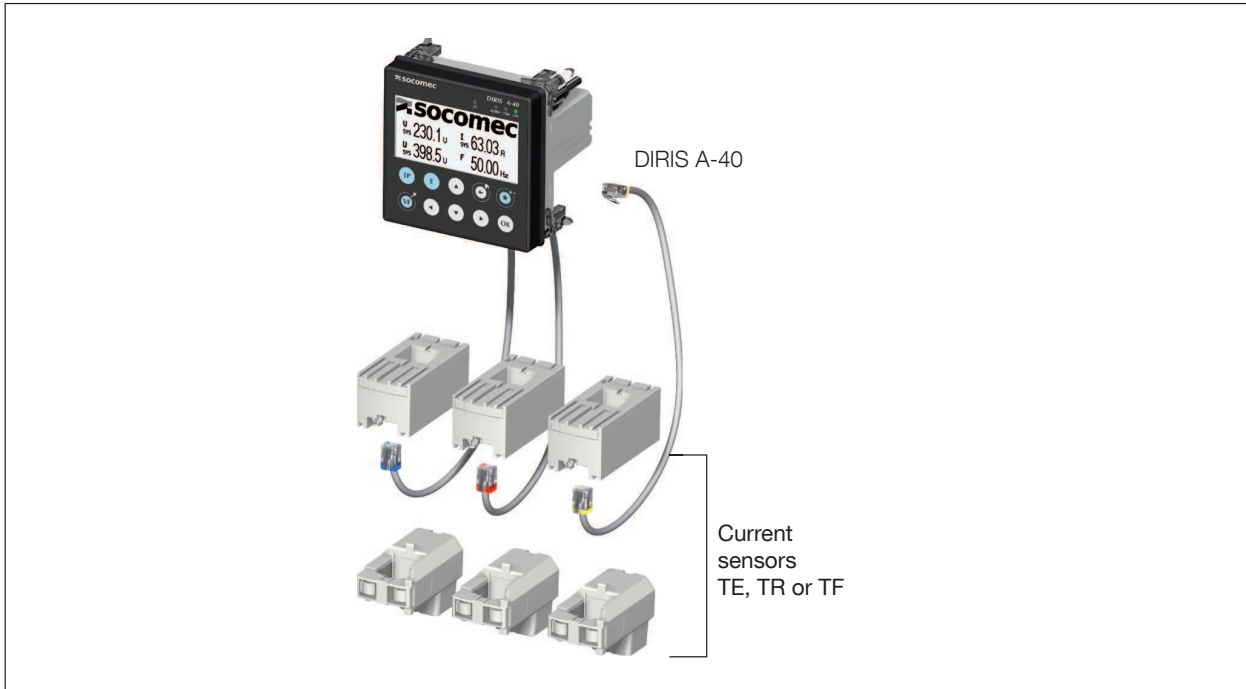

For connecting the current sensors, use SOCOMEC cables only, RJ12 straight cables, twisted pair, unshielded, 600 V, -10°C / +70°C.

It is recommended that all the current sensors are installed in the same direction.

### Connection cables for current sensors:

RJ12 connection cables	Cable length (m)								
	0.1	0.2	0.3	0.5	1	2	5	10	50 m reel + 100 connectors*
Number of cables	Part number	Reference	Reference	Reference	Reference	Reference	Reference	Reference	Reference
1	-	-	-	-	-	-	4829 0602	4829 0603	4829 0601
3	4829 0580	4829 0581	4829 0582	4829 0595	4829 0583	4829 0584	-	-	-
4				4829 0596	4829 0588	4829 0589	-	-	-
6	4829 0590	4829 0591	4829 0592	4829 0597	4829 0593	4829 0594	-	-	-





\* When producing cables, do not exceed a maximum length of 10 metres.

## 4.2.1. TE solid-core current sensors

The TE solid-core current sensors are used to set up measurement points in a new or existing installation. They are easy to integrate as they are compact and respect the pitch of the circuit breakers. A wide range of accessories are also available for easy direct fitting on all type of cabling (cable, flexible or rigid busbar) or on a DIN rail support or plate.

Thanks to the specific link, they are recognised by the DIRIS A-40 and a high level of overall accuracy for the measurement chain is guaranteed.

### 4.2.1.1. Range

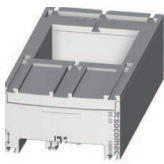
						
	<b>TE-18</b>	<b>TE-18</b>	<b>TE-25</b>	<b>TE-35</b>	<b>TE-45</b>	<b>TE-55</b>
<b>Pitch</b>	18 mm	18 mm	25 mm	35 mm	45 mm	55 mm
<b>Nominal current range <math>I_n</math></b>	5 - 20 A	25 - 63 A	40 - 160 A	63 - 250 A	160 - 630 A	400 - 1000 A
<b>Maximum I</b>	24 A	75.6 A	192 A	300 A	756 A	1200 A
<b>Reference</b>	4829 0500	4829 0501	4829 0502	4829 0503	4829 0504	4829 0505

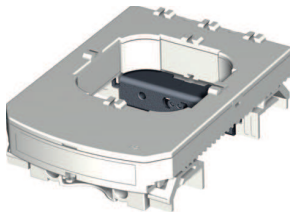
	
	<b>TE-90</b>
<b>Pitch</b>	90 mm
<b>Nominal current range <math>I_n</math></b>	600 - 2000 A
<b>Maximum I</b>	2400 A
<b>Reference</b>	4829 0506

4.2.1.2. Dimensions

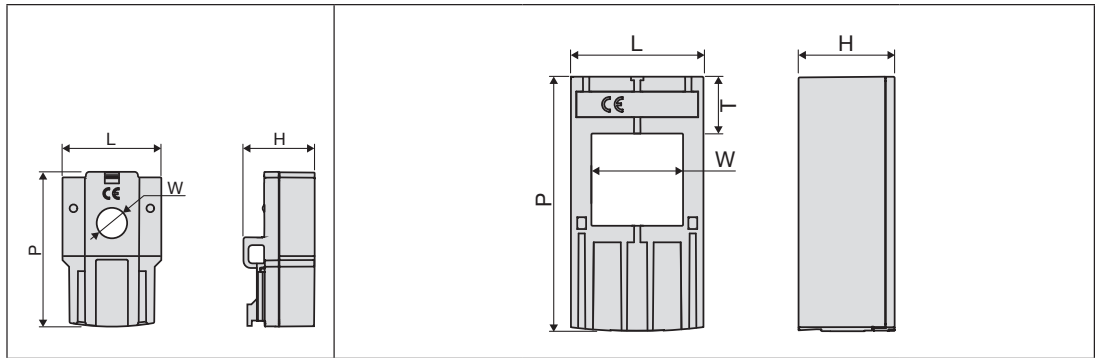

Dimensions in/mm	TE-18	TE-25	TE-35	TE-45	TE-55
<b>Pitch</b>	0.71 18 (staggered assembly)	0.98 25	1.37 35	1.77 45	2.16 55
<b>LxHxD</b>	1.10 x 0.79 x 1.77 28 x 20 x 45	0.98 x 1.28 x 2.56 25 x 32.5 x 65	1.37 x 1.28 x 2.79 35 x 32.5 x 71	1.77 x 1.28 x 3.38 45 x 32.5 x 86	2.16 x 1.28 x 3.93 55 x 32.5 x 100
<b>Aperture (W)</b>	∅ 0.33 ∅ 8.4	0.53 x 0.53 13.5 x 13.5	0.82 x 0.82 21 x 21	1.22 x 1.22 31 x 31	1.61 x 1.61 41 x 41
<b>(T)</b>	-	0.69 17.5	0.69 17.5	0.77 19.5	0.85 21.5

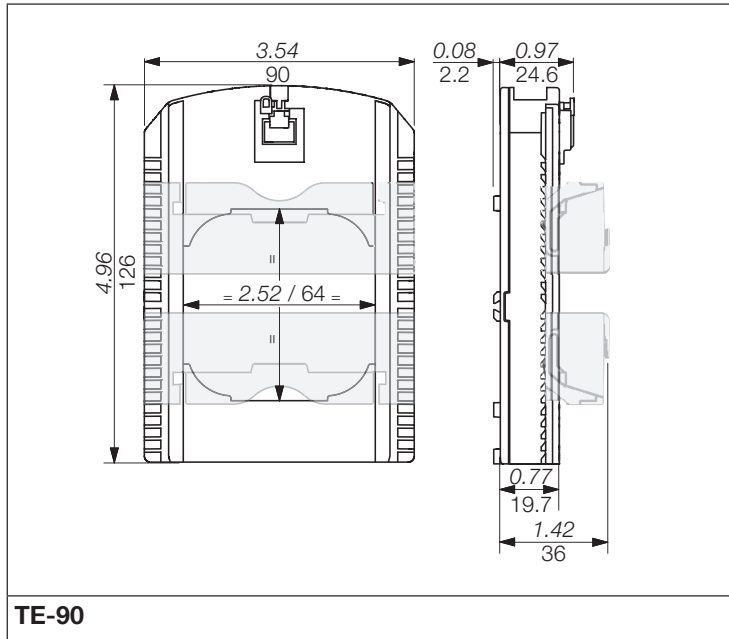





## 4.2.2. TR / iTR split-core current sensors

The TR / iTR split-core current sensors are used to set up measurement points in a new or existing installation without interfering with its cabling. Thanks to the specific link, they are recognised by the DIRIS A-40 and the overall accuracy of the measurement chain is guaranteed.

In addition, iTR sensors detect the presence of a voltage in the cable passing through them.

### 4.2.2.1. Range

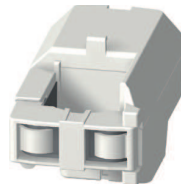
Four models are available from 25A to 600A to analyse several types of loads.

				
	<b>TR-10 / iTR-10</b>	<b>TR-14 / iTR-14</b>	<b>TR-21 / iTR-21</b>	<b>TR-32 / iTR-32</b>
<b>Cable passage diameter</b>	diameter 10 mm	diameter 14 mm	diameter 21 mm	diameter 32 mm
<b>Nominal current range In</b>	25 - 63 A	40 - 160 A	63 - 250 A	160 - 600 A
<b>Maximum I</b>	75.6 A	192 A	300 A	720 A
<b>Reference</b>	4829 0555 / 4829 0655	4829 0556 / 4829 0656	4829 0557 / 4829 0657	4829 0558 / 4829 0658

### 4.2.2.2. Dimensions

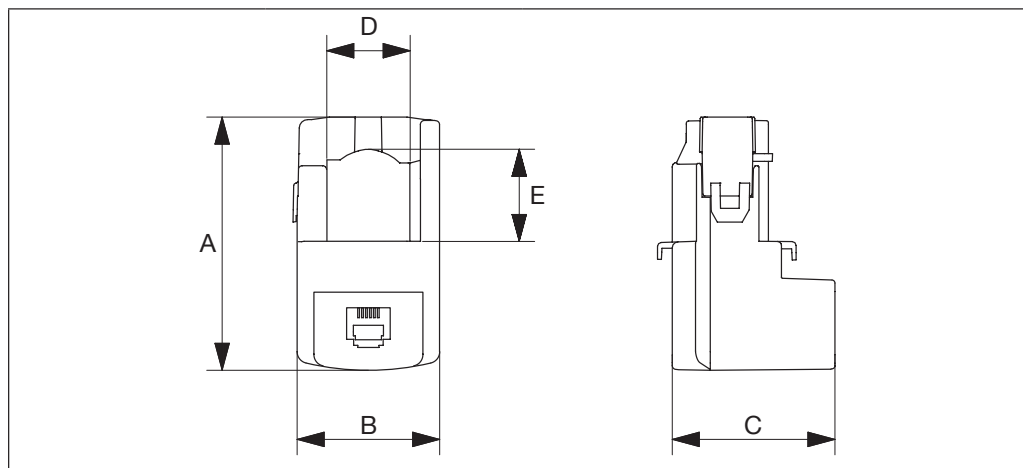

Dimensions in/mm	<b>TR-10 / i TR-10</b>	<b>TR-14 / i TR-14</b>	<b>TR-21 / iTR-21</b>	<b>TR-32 / iTR-32</b>
<b>A</b>	1.74 44	2.63 67	2.56 65	3.38 86
<b>B</b>	1.02 26	1.14 29	1.45 37	2.08 53
<b>C</b>	1.10 28	1.10 28	1.69 43	1.85 47
<b>D</b>	-	0.55 14	0.82 21	1.26 32
<b>T</b>	-	0.59 15	0.90 23	1.30 33
<b>Diameter</b>	0.39 10	0.55 14	0.82 21	1.26 32



### 4.2.3. TF flexible current sensors

The TF flexible current sensors use the Rogowski principle which enables a large current range to be covered without saturation. Flexible design and easy-opening system for quick installation in electrical enclosures. They are particularly suitable for adding measuring points in existing installations and for test campaigns.

#### 4.2.3.1. Range

Three models are available, covering a large current range up to 6000 A with openings of different shapes and sizes.

An integrator will be required to shape the current signal. Thanks to the specific link, they are recognised by the DIRIS A-40 and the overall accuracy of the measurement chain is guaranteed.

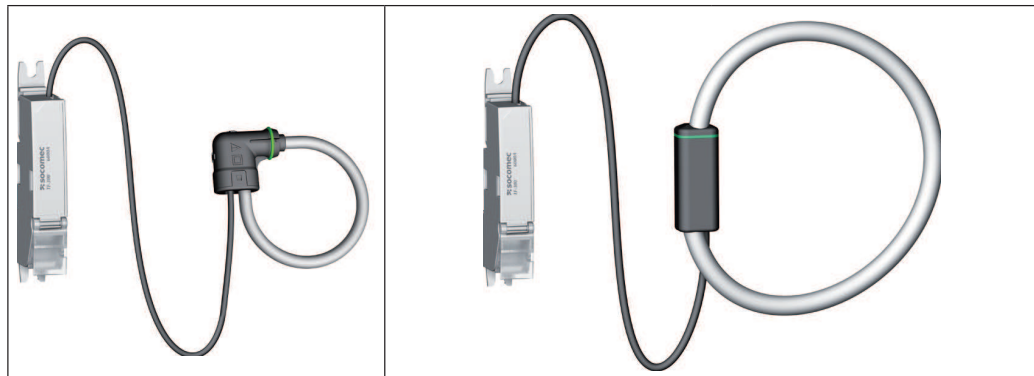

	<b>TF-55</b>	<b>TF-120</b>	<b>TF-300</b>
<b>Loop length</b>	55 mm	120 mm	300 mm
<b>Nominal current range In</b>	150 - 600 A	500 - 2000 A	1600 - 6000 A
<b>Reference</b>	4829 0570	4829 0571	4829 0572

#### 4.2.3.2. Dimensions

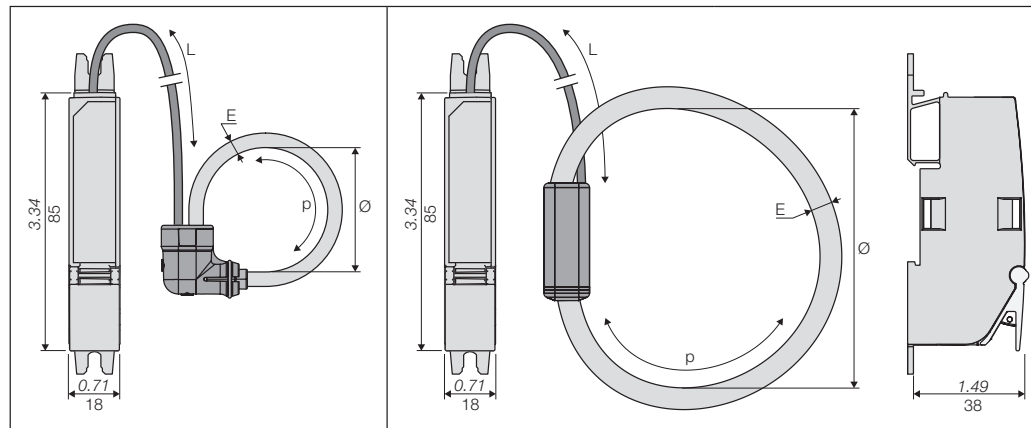

Dimensions in/mm	<b>TF-55</b>	<b>TF-120</b>	<b>TF-300</b>
<b>Diameter</b>	2.16 55	4.72 120	11.81 300
<b>P</b>	7.16 182	14.80 376	37.08 942
<b>T</b>	0.23 6	0.43 11	0.43 11
<b>L</b>		59.05 1500	

#### 4.2.4. Adapters for 5A sensors

The adapter lets you use a standard sensor supplying a 1A or 5A current to the secondary sensor. When this kind of sensor is used, the overall accuracy of the DIRIS A-40 + sensor is not guaranteed and will depend on the accuracy of the associated sensor (see standard "IEC 61557-12" for more information).  
The primary current is max. 10000A / 5A or 2000A / 1A.

##### 4.2.4.1. Range

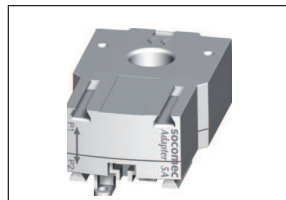

**5A adapter**

<b>I nom.</b>	5 A
<b>I max.</b>	6 A
<b>Reference</b>	4829 0599

##### 4.2.4.2. Dimensions

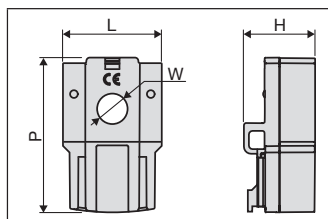

Dimensions in/mm

**5A adapter**

<b>LxHxD</b>	1.10 x 0.79 x 1.77 28 x 20 x 45
<b>Aperture (W)</b>	∅ 0.33 ∅ 8.4

## 5. INSTALLATION

The following paragraphs describe the installation of the DIRIS A-40 and associated sensors.

### 5.1. Recommendations and safety

Refer to the safety instructions (section "2. Hazards and warnings", page 4)

- Keep away from electromagnetic interference generator systems.
- Avoid vibrations with accelerations greater than 1 g for frequencies lower than 60 Hz.
- The device must not be cleaned.
- Do not install outdoor.

### 5.2. Installing DIRIS A-40

The DIRIS A-40 is to be fitted onto a door with a 92x92 mm cutout.

Dimensions: *in/mm*

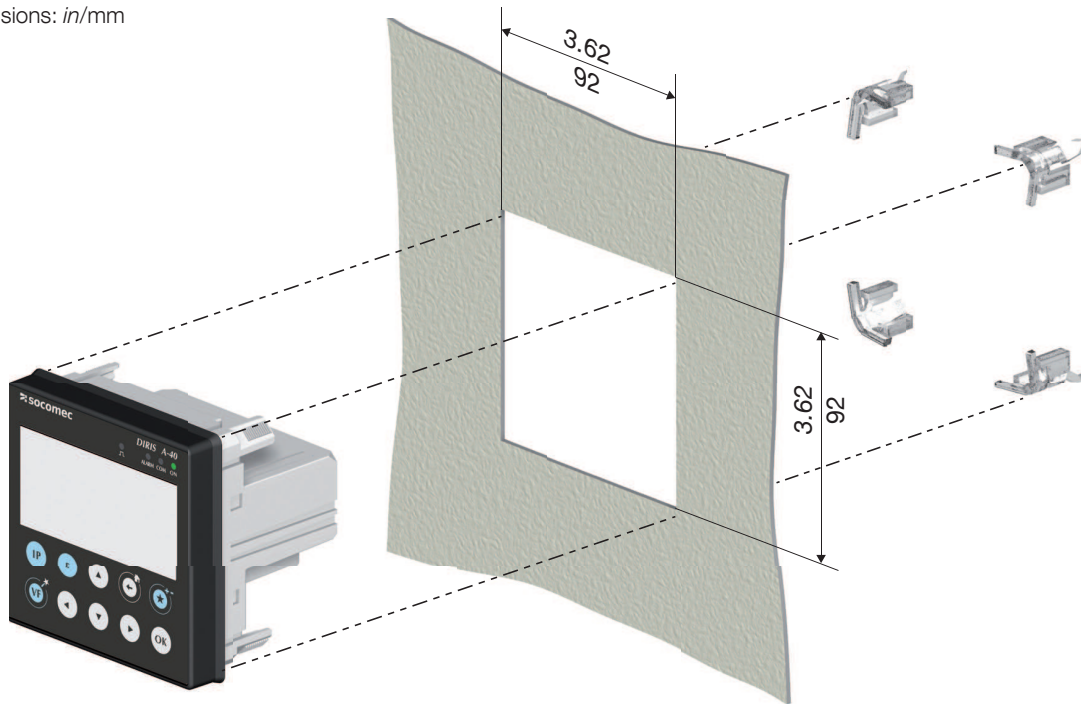

## 5.3. Installing TE solid-core sensors

### 5.3.1. Mounting accessories

The list of mounting accessories supplied with the sensors are listed below:

Reference		Pitch	DIN rail and plate mounting	DIN rail mounting	Plate mounting	Busbar mounting
4829 0500 4829 0501	<b>TE-18</b>	<b>18 mm</b>	x1			
4829 0502	<b>TE-25</b>	<b>25 mm</b>		x2	x4	
4829 0503	<b>TE-35</b>	<b>35 mm</b>		x2	x4	x2
4829 0504	<b>TE-45</b>	<b>45 mm</b>		x2	x4	x2
4829 0505	<b>TE-55</b>	<b>55 mm</b>		x2	x4	x2
4829 0506	<b>TE-90</b>	<b>90 mm</b>	x2		x6	

### 5.3.2. DIN rail mounting

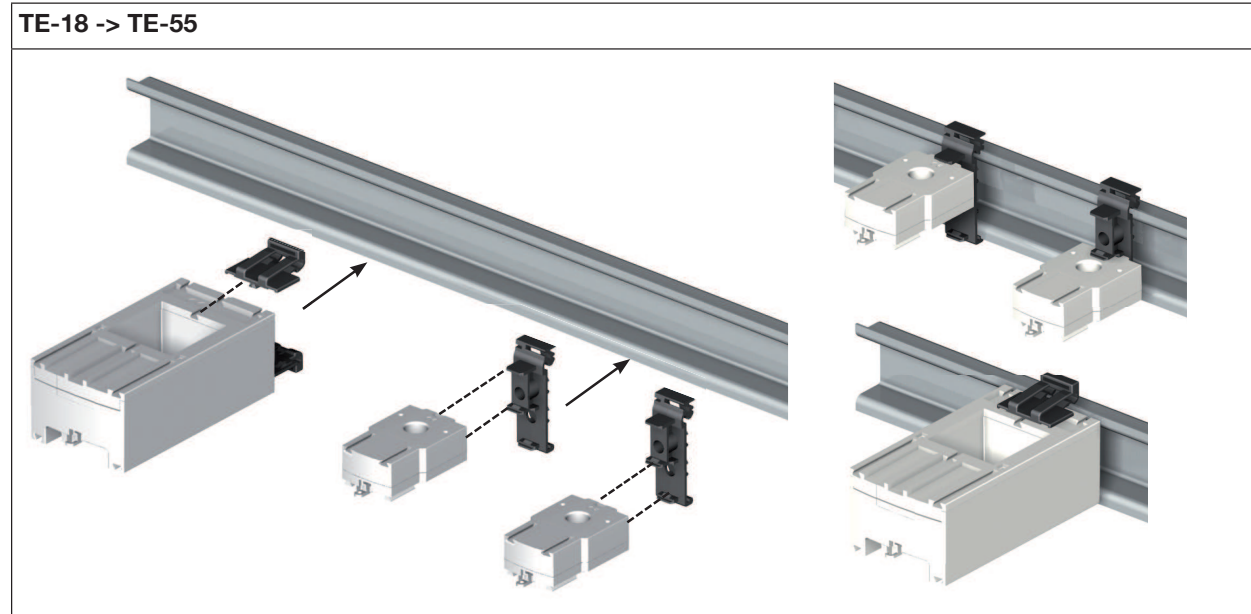

## TE-90

Removing clamps

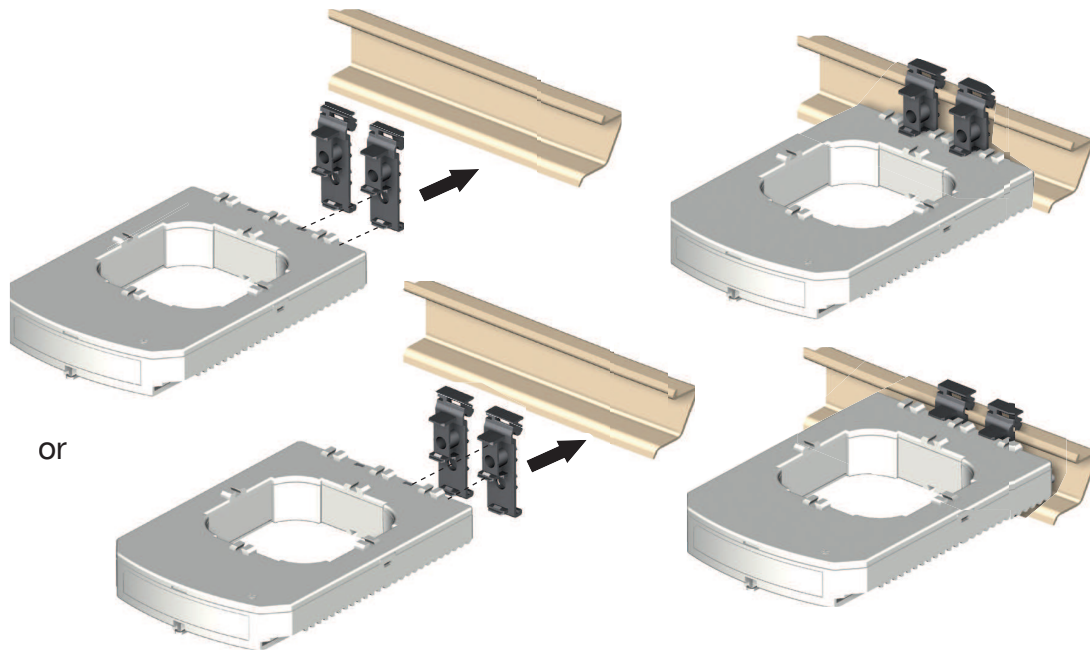
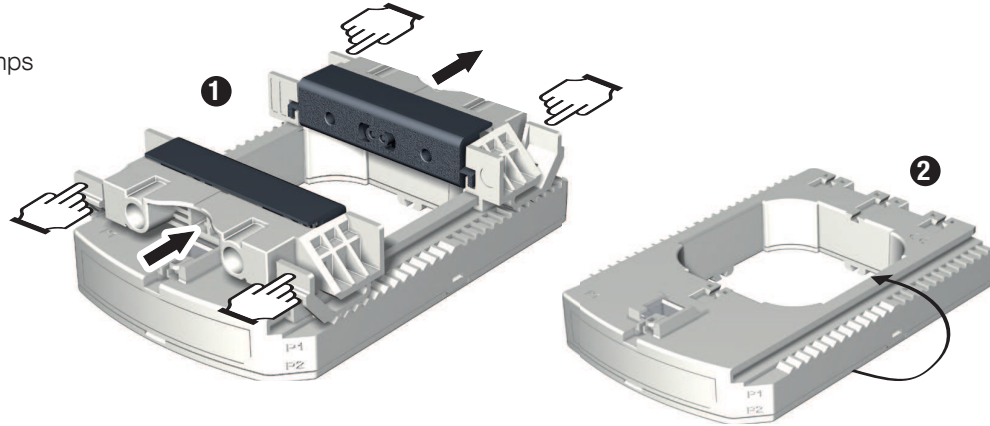

NB: Fix sensor TE-90 to the DIN rail to make it easier to install. This is a temporary installation. Use the clamps to install the TE-90 sensors on the DIN rail.

### 5.3.3. Plate mounting

#### TE-18

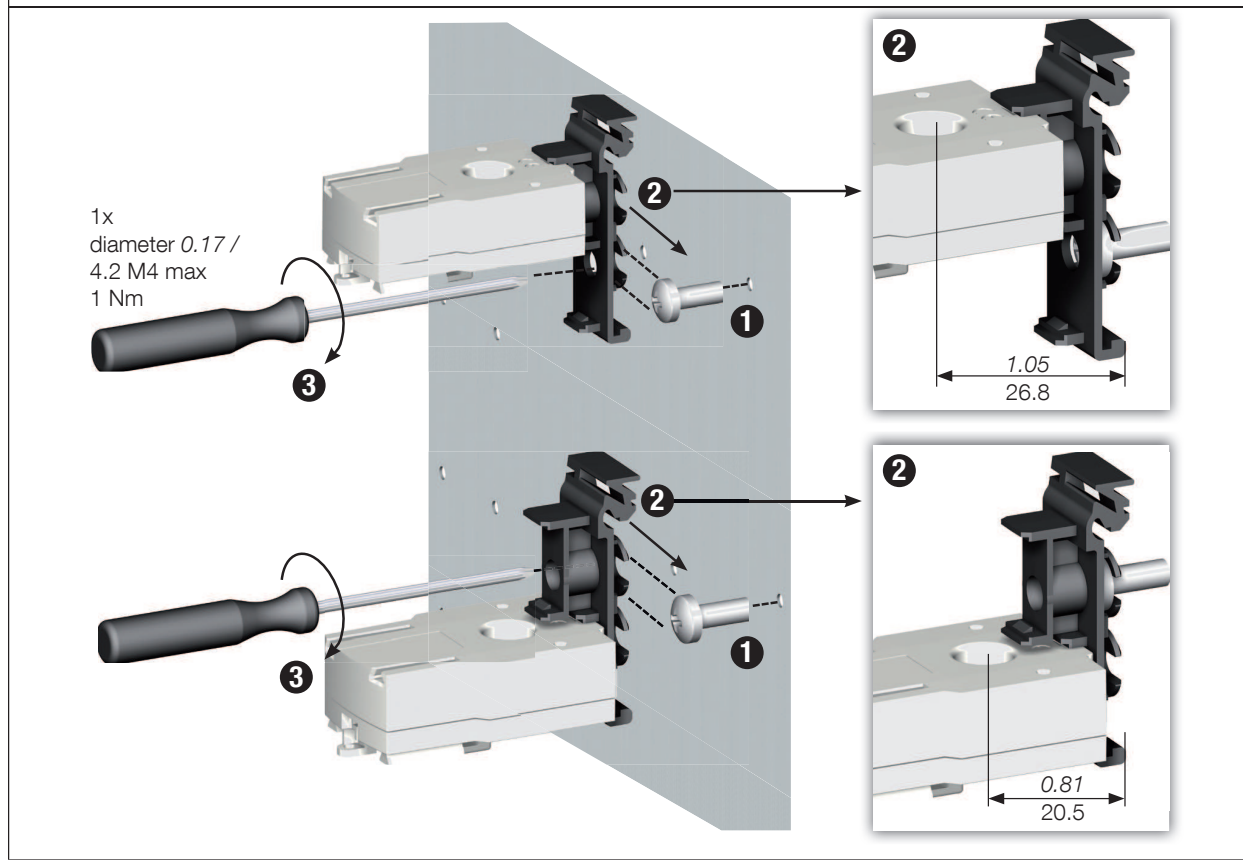

#### TE-25 -> TE-55

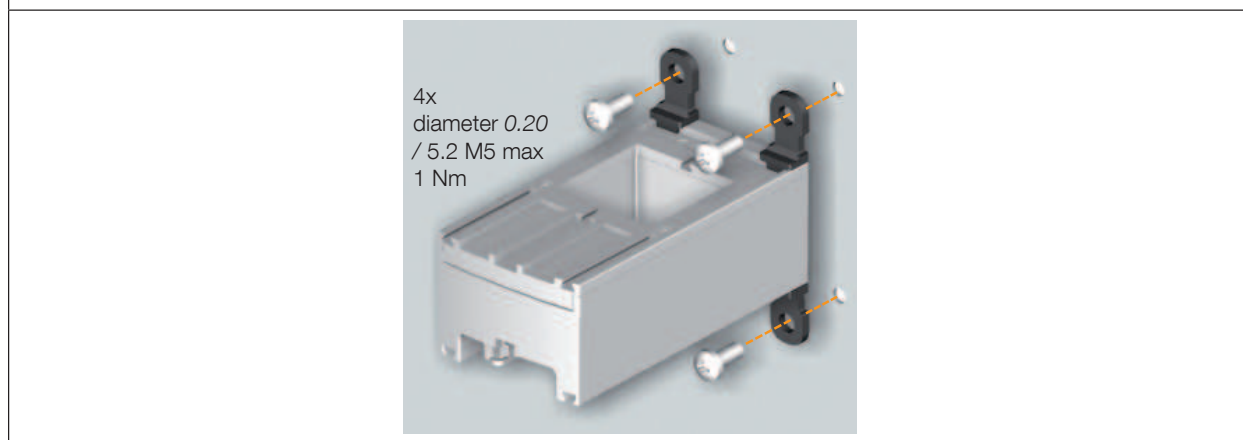

## TE-90

Removing clamps

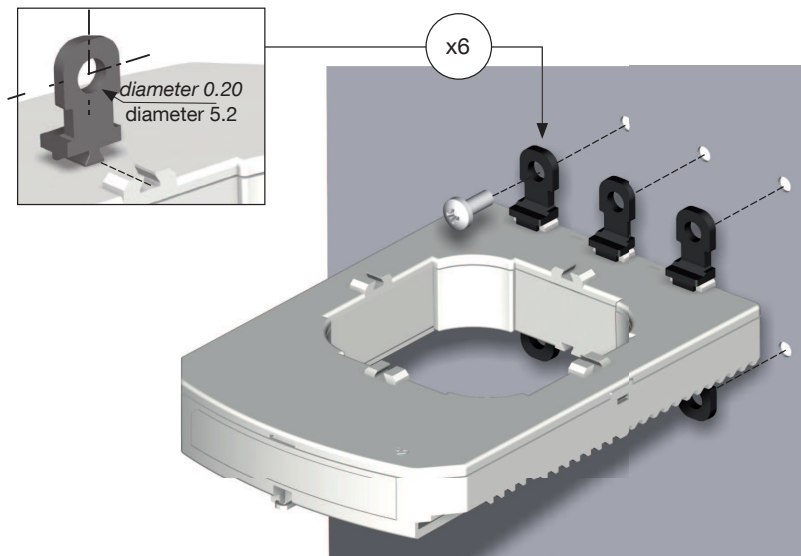
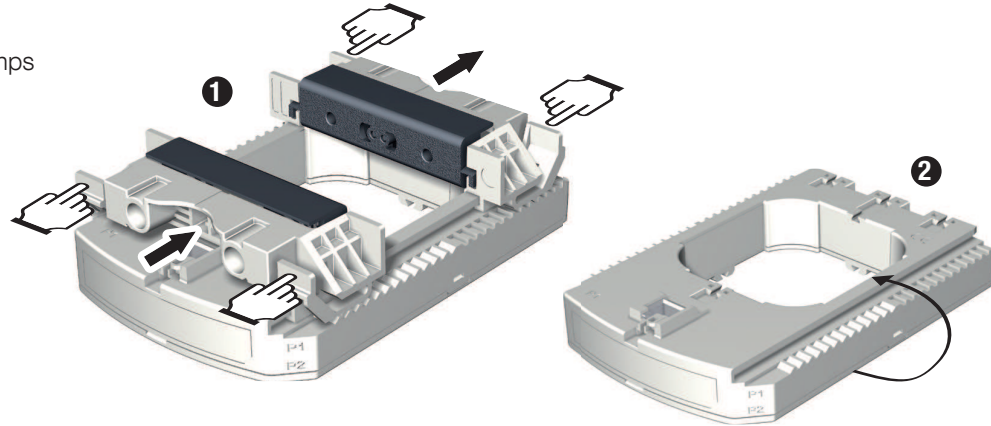

NB: Use the clamps to install the TE-90 sensors on the board.

### 5.3.4. Installing on a cable with clamping collar

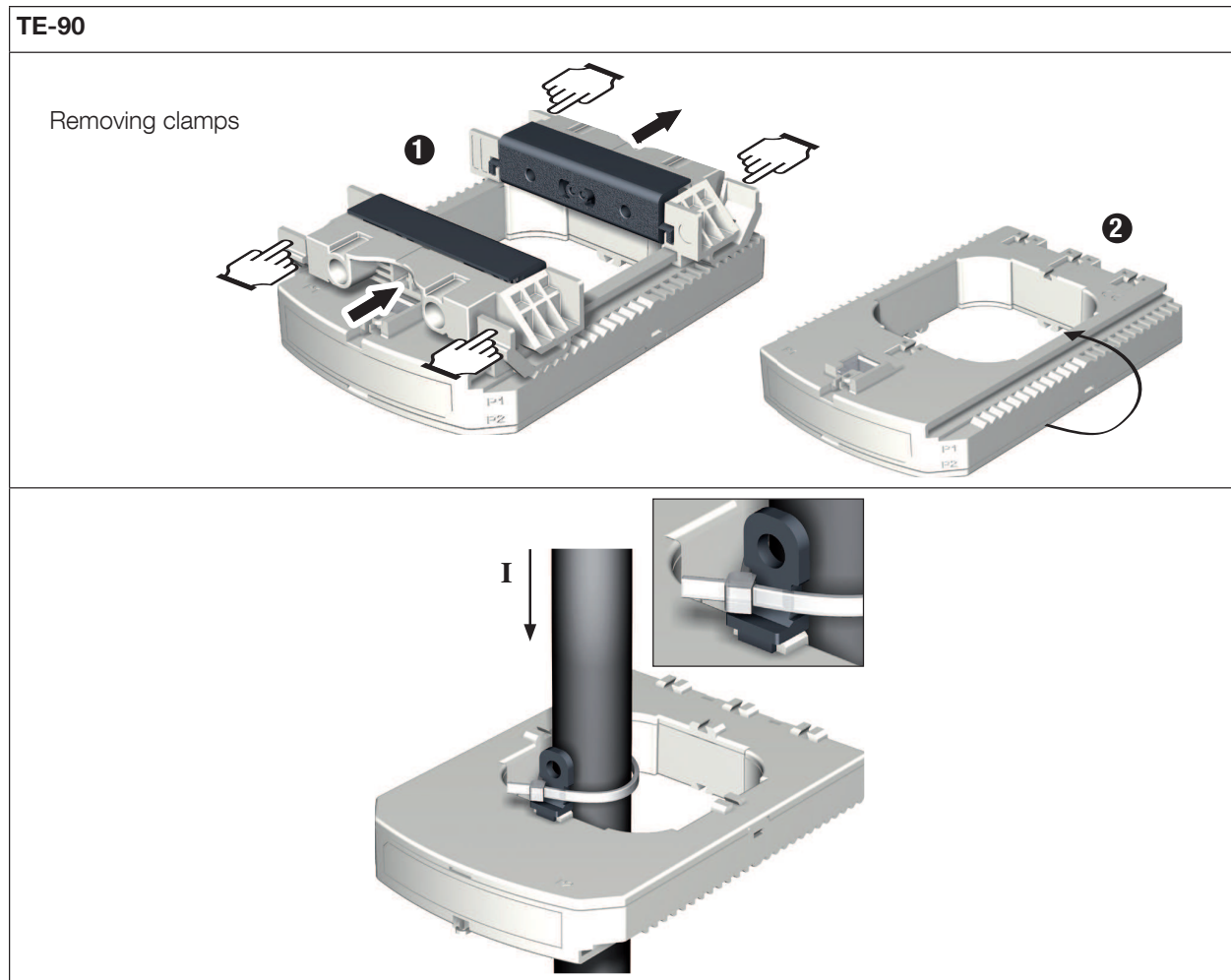
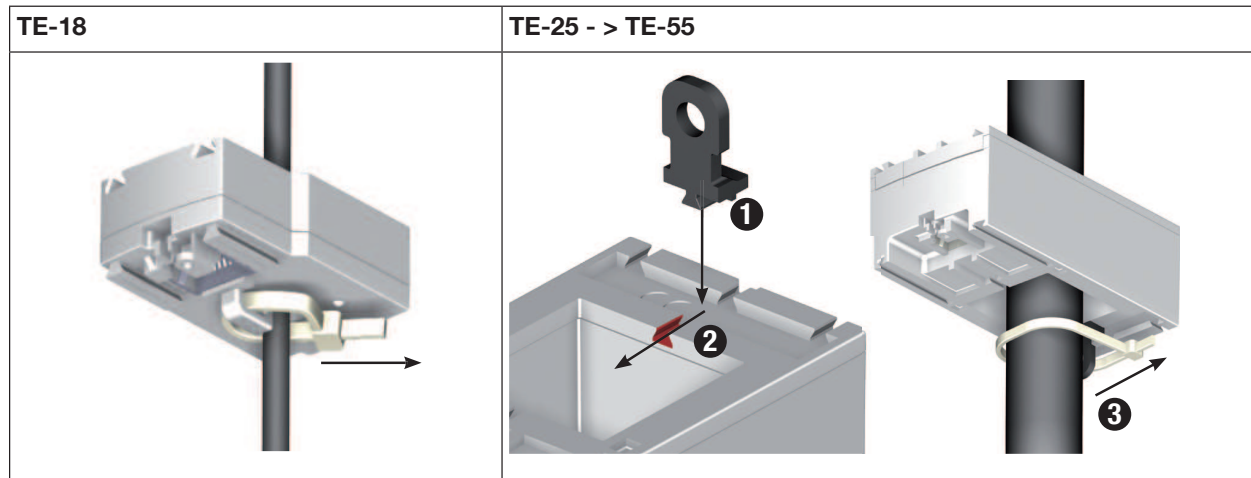

NB: Use the clamps to install the TE-90 sensors on a cable with clamping collar.

	<p>Do NOT clamp or pull out NON-INSULATED conductors carrying DANGEROUS VOLTAGE which could cause an electric shock, burn or arc flash. Ref. IEC 61010-2-032</p>
---	--



### 5.3.5. Bar mounting

TE-35 -> TE-55

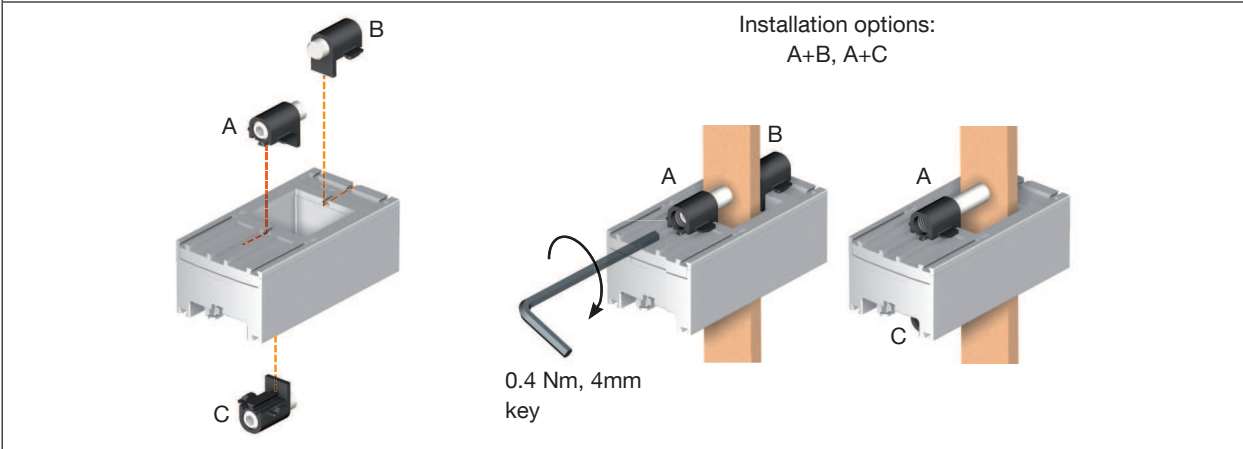

TE-90

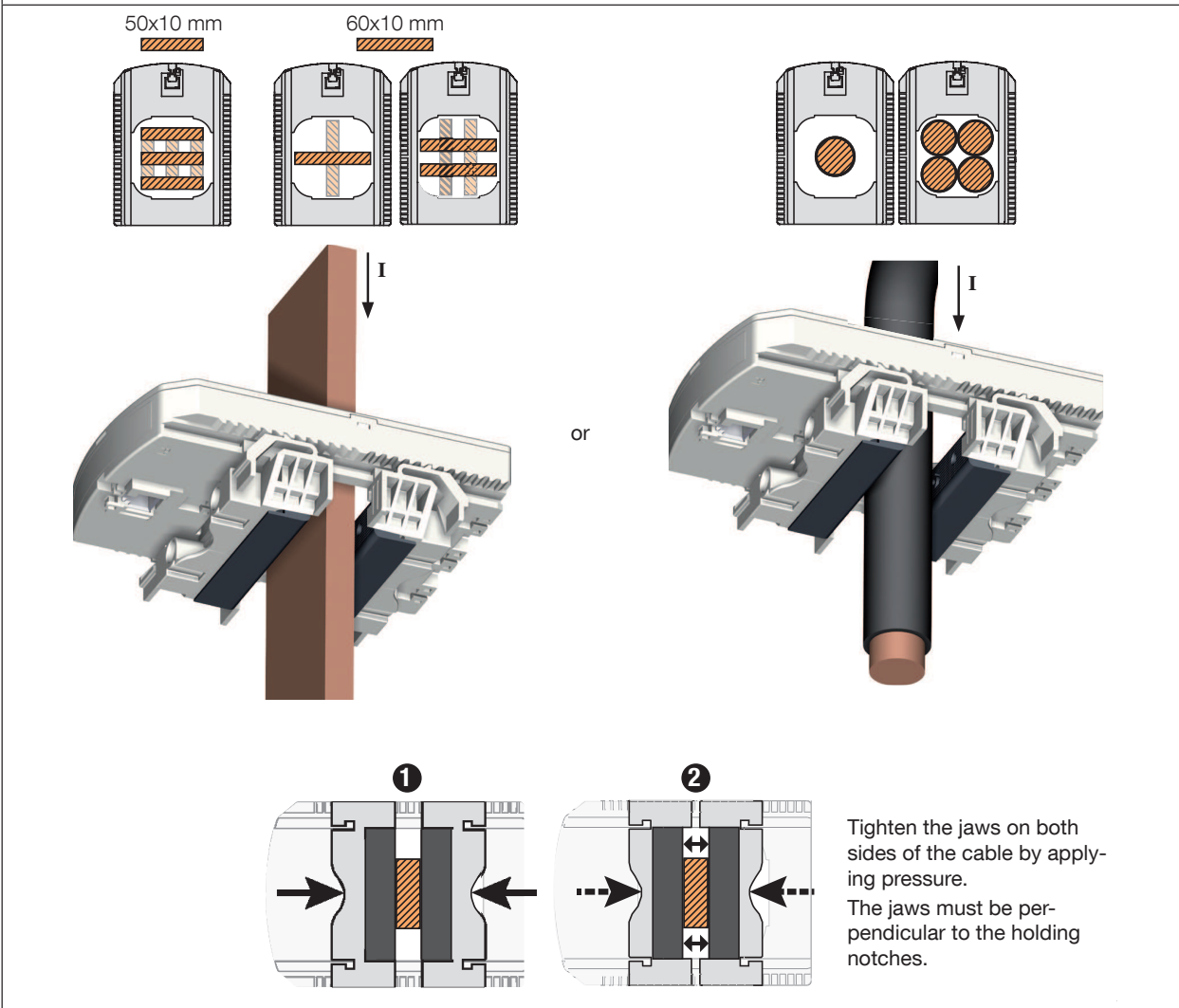

Do NOT clamp or pull out NON-INSULATED conductors carrying DANGEROUS VOLTAGE which could cause an electric shock, burn or arc flash.  
Ref. IEC 61010-2-032

### 5.3.6. Sensors assembly

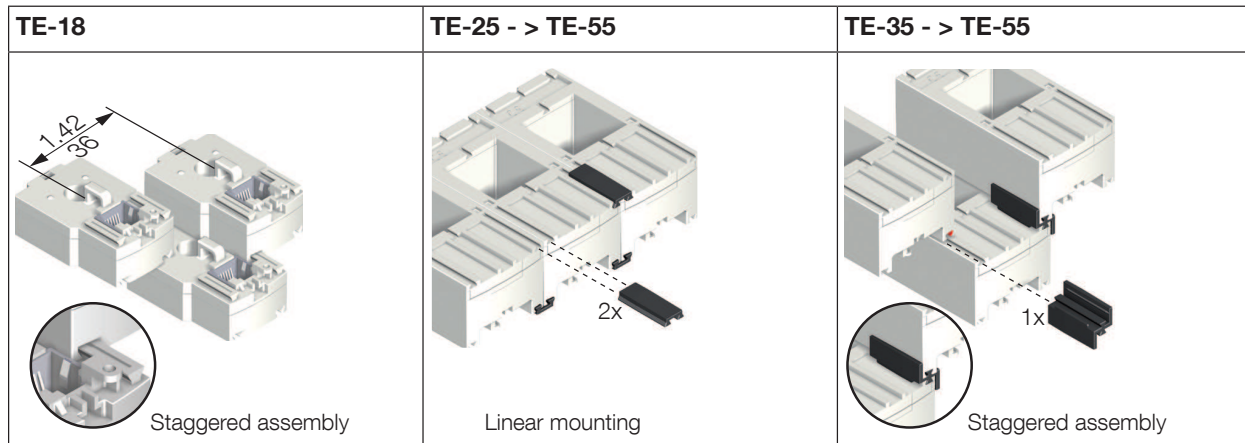

Mounting accessories for sensor combination:

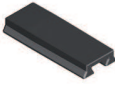
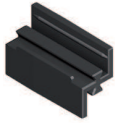
		
<b>Reference</b>	Linear assembly	Staggered assembly
4829 0598	x30	

These accessories must be ordered separately.

### 5.3.7. Sealing accessories for sensors

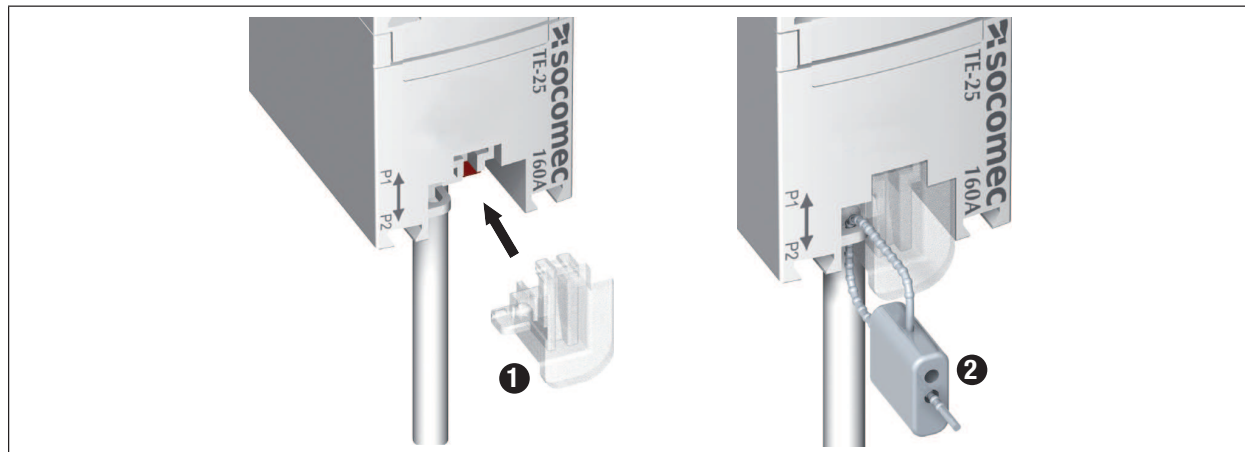

<b>Reference</b>	Sealing case for terminal
4829 0600	x20

These accessories must be ordered separately.

## 5.4. Installing TR split-core sensors

### 5.4.1. Cable mounting

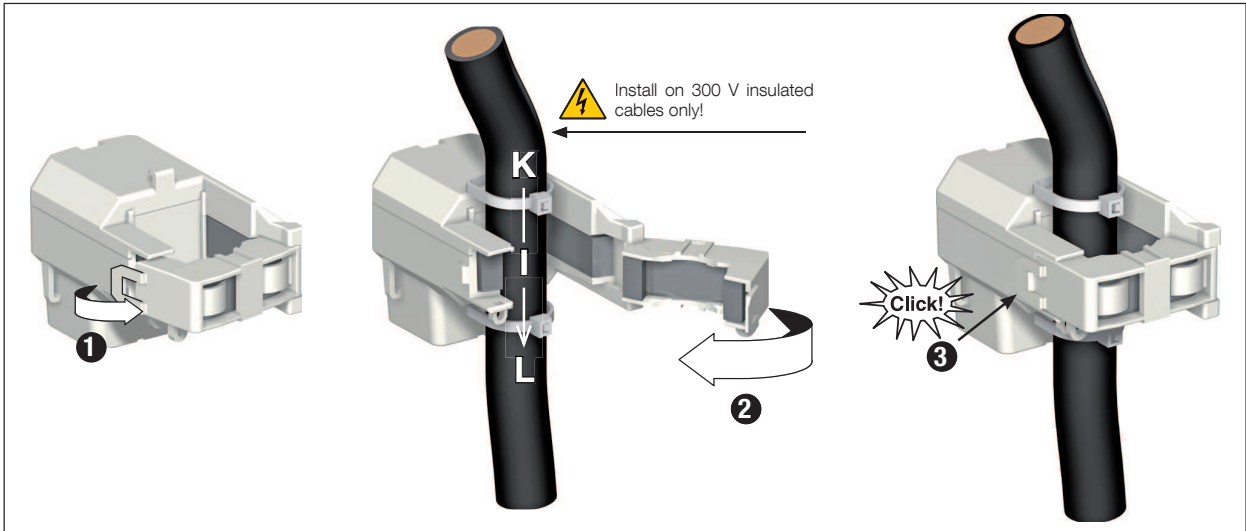

Do NOT clamp or pull out NON-INSULATED conductors carrying DANGEROUS VOLTAGE which could cause an electric shock, burn or arc flash.  
Ref. IEC 61010-2-032



Before closing the TR sensor, check that the air gap is clean (no contamination or corrosion)

## 5.5. Flexible TF sensors mounting

### 5.5.1. Installing the casing

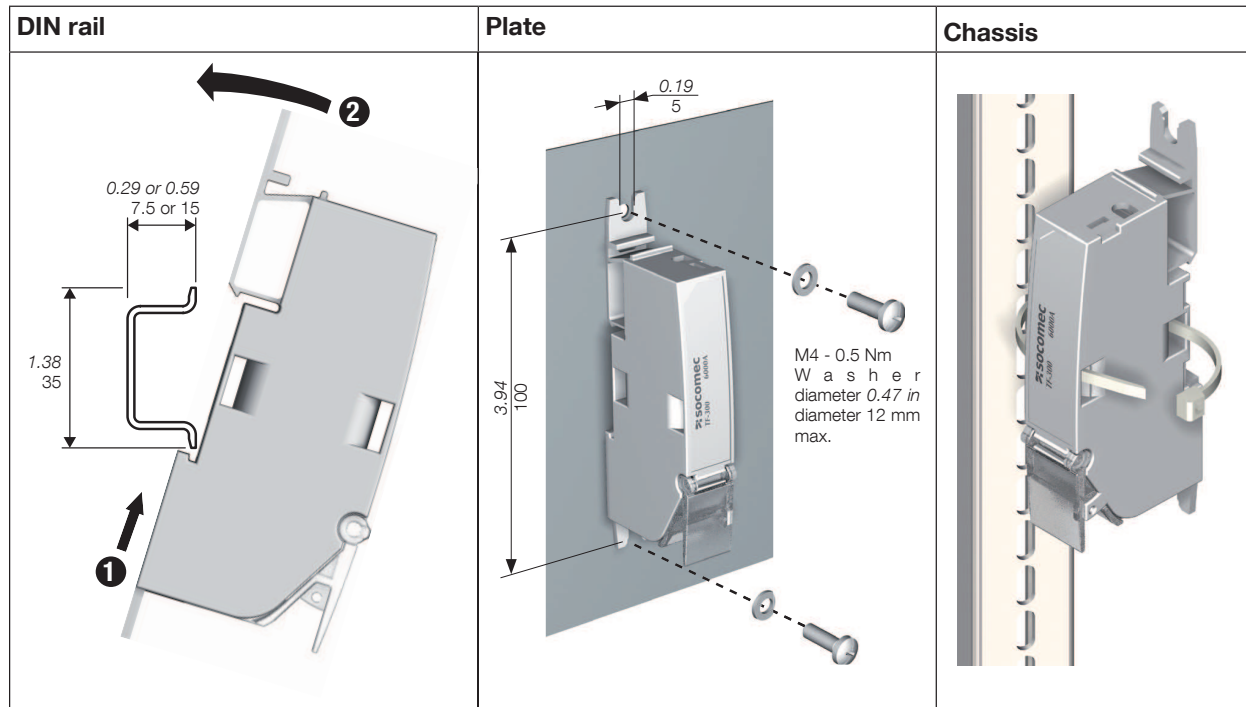

### 5.5.2. Cable mounting

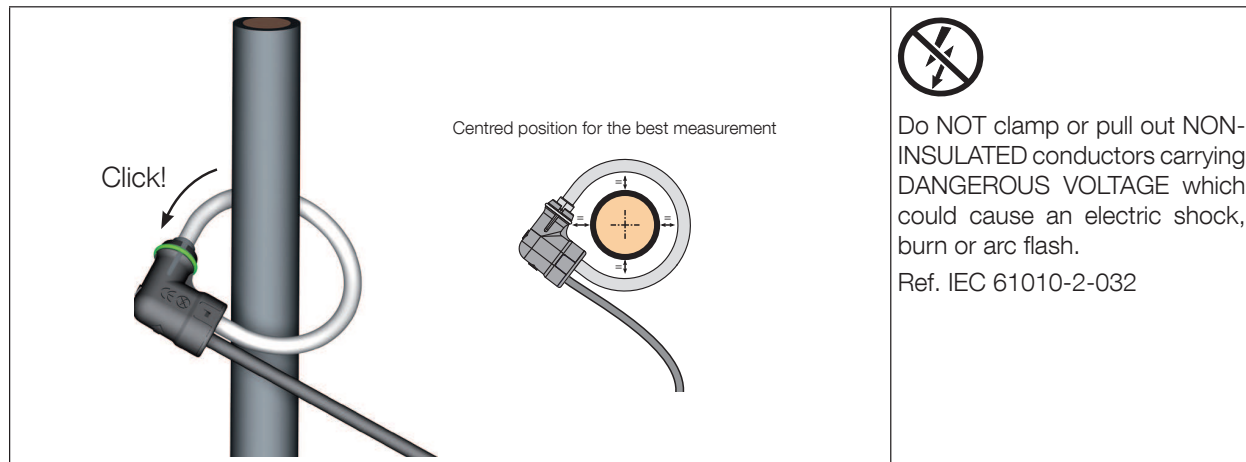

### 5.5.3. Bar mounting

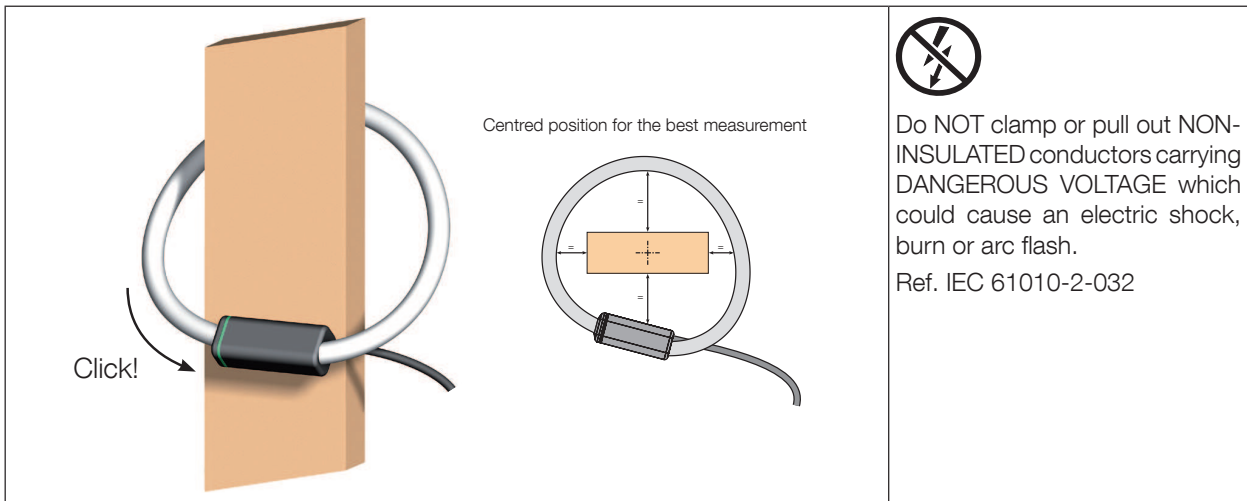

### 5.6. Installing the 5A adapter

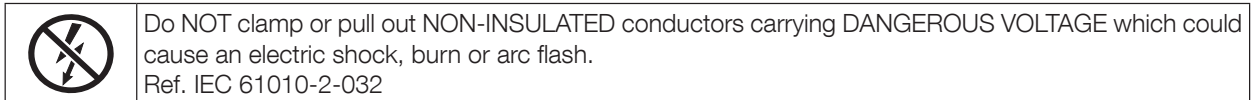
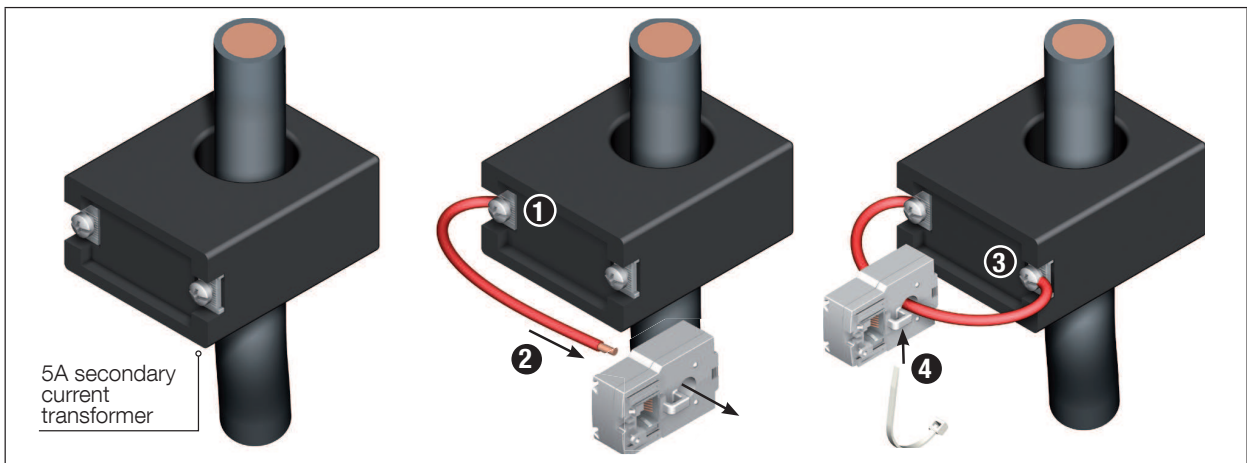

# 6. CONNECTION

## 6.1. DIRIS A-40 connection

DIRIS A-40 ref. 4825 0501

①	2x OUTPUT 30 VDC - 20 mA max. - SELV	x= 7 mm 0.14 mm <sup>2</sup> - 1.5 mm <sup>2</sup>	0.25 N.m max.
②	3x INPUT 12 VDC - 27 mA max. - SELV	x= 7 mm 0.14 mm <sup>2</sup> - 1.5 mm <sup>2</sup>	0.25 N.m max.
③	RS485 MODBUS SELV	x= 7 mm 0.14 mm <sup>2</sup> - 1.5 mm <sup>2</sup>	0.25 N.m max.
④	SUPPLY 110-400 VAC 50-60Hz 120-300 VDC	x= 7 mm 0.2 mm <sup>2</sup> - 2.5 mm <sup>2</sup>	0.6 N.m max.
⑤	V1-V2-V3-VN 50-300 VAC (Ph/N) 87-520 VAC (Ph/Ph)	x= 7 mm 0.2 mm <sup>2</sup> - 2.5 mm <sup>2</sup>	0.6 N.m max.
⑥	ETHERNET (Ref 4825 0501) PROFIBUS (Ref 4825 0502)	-	-
⑦		x= 8 mm 0.2 mm <sup>2</sup> - 4 mm <sup>2</sup>	0.6 N.m max.

3x | TE / TR / TF sensors

SELV: Safety Extra Low Voltage

DIRIS A-40 ref. 4825 0500

DIRIS A-40 ref. 4825 0502

## Description of the terminals

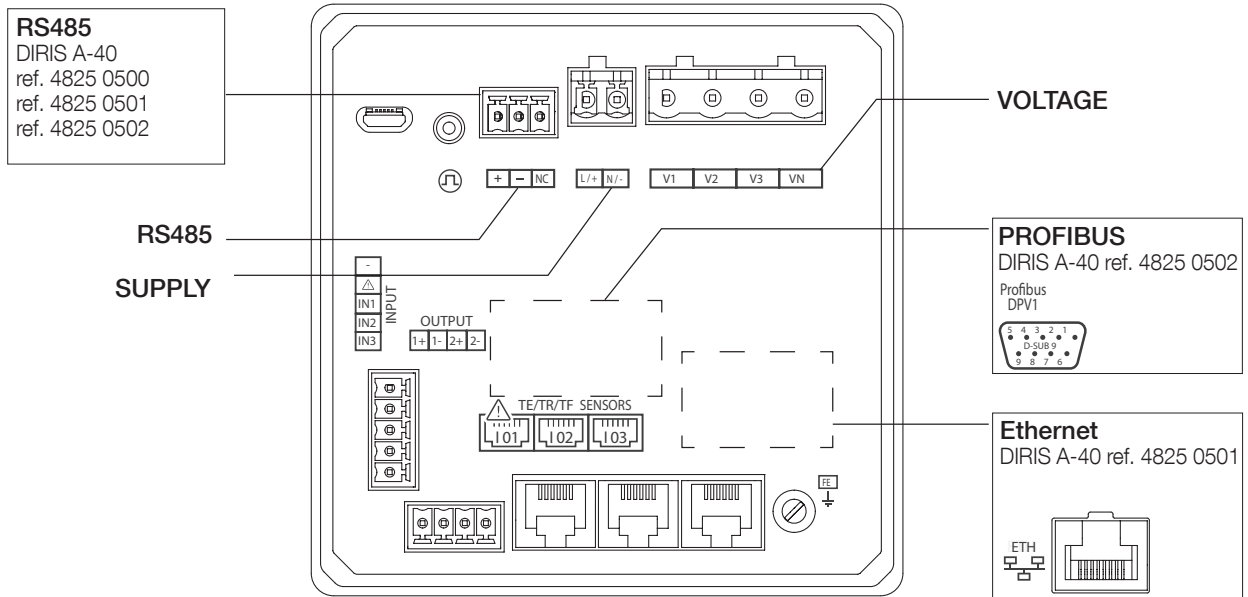

### SUPPLY ④

#### Auxiliary power supply

110-277VAC L/N 50-60Hz  
277-400VAC L/L' 50-60Hz  
120-300 VDC

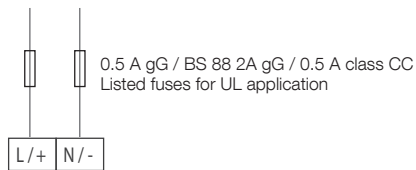

### TE/TR/TF SENSORS

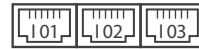

### Digital inputs

#### 3x INPUT ②

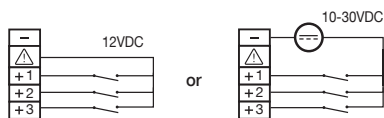

### Digital outputs

#### 2x OUTPUT ①

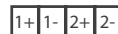

### Communication ③ ⑥

#### RS485 MODBUS

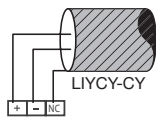

#### PROFIBUS



- 1: NC
- 2: NC
- 3: B
- 4: NC
- 5: GND
- 6: VCC
- 7: NC
- 8: A
- 9: NC

#### ETHERNET

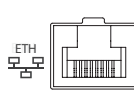

Means to prevent loosening of the conductors must be fitted on the nearest of the connections.

## 6.2. Connection to the electrical network and to the loads

The DIRIS A-40 can be used on single-phase, two-phase or three-phase networks.

### 6.2.1. Configurable loads based on the network type

The table below summarises the load that it is possible to configure depending on the type of network at the installation.

Network type	Configurable load
1P+N single-phase	1P+N - 1CT
2P two-phase	2P - 1CT
2P+N two-phase	2P+N - 2CT
3P three-phase	3P - 3CT / 3P - 2CT / 3P - 1CT
3P+N three-phase	3P+N - 3CT / 3P+N - 1CT

### 6.2.2. Description of the main network and load combinations

Legend:

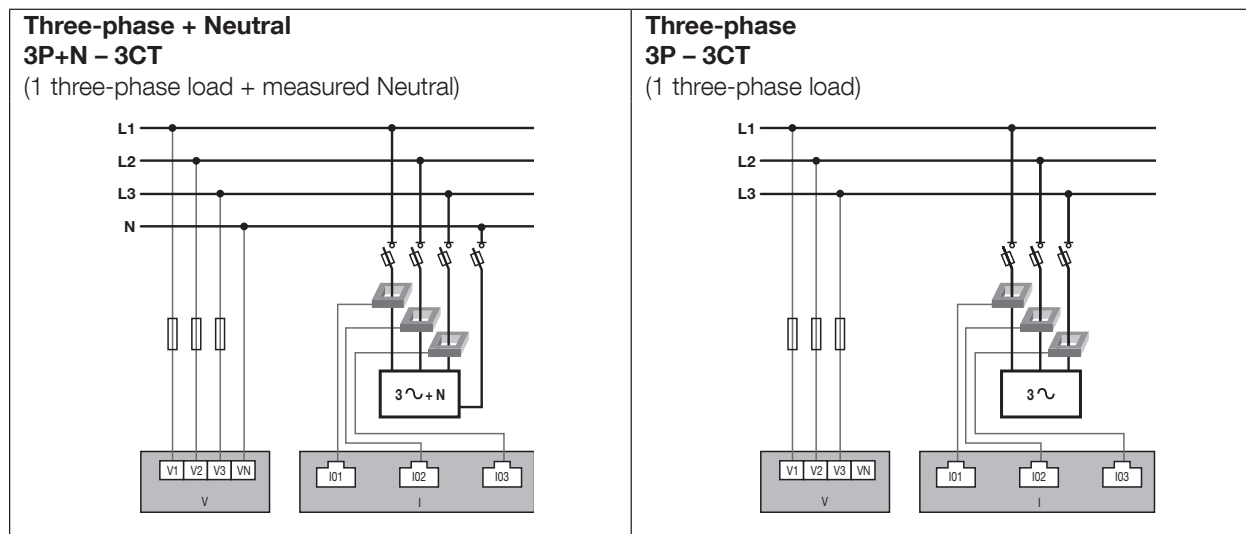
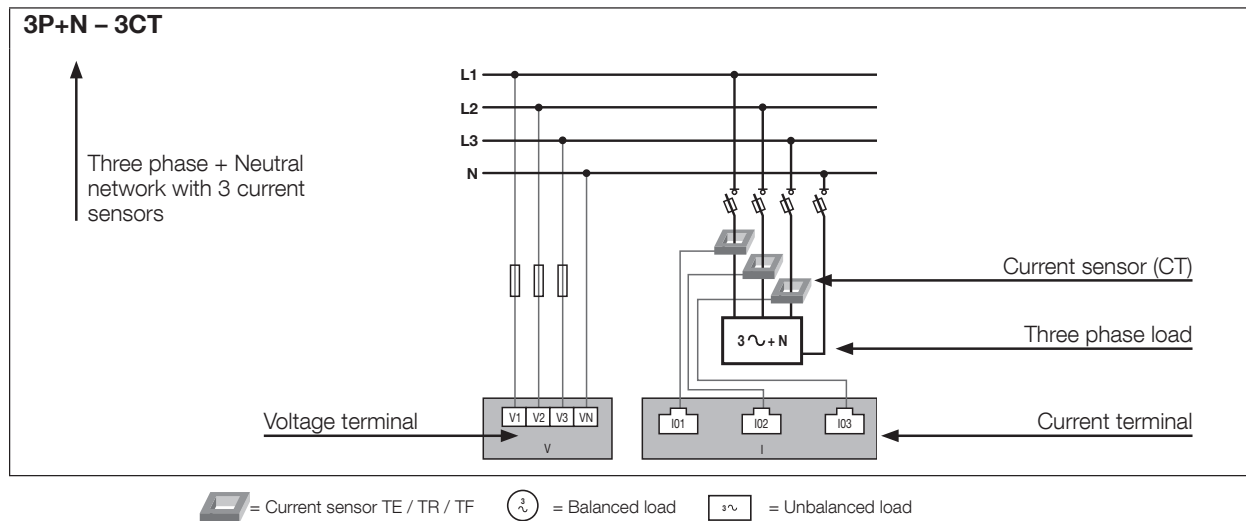



**Three-phase**

**3P - 2CT**

(1 unbalanced three-phase load)

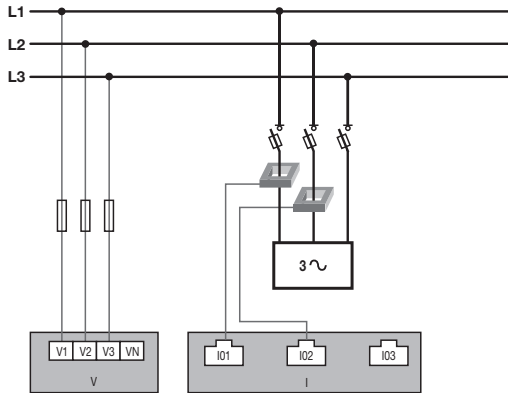

**Three-phase**

**3P+N - 1 CT**

(1 balanced three-phase load)

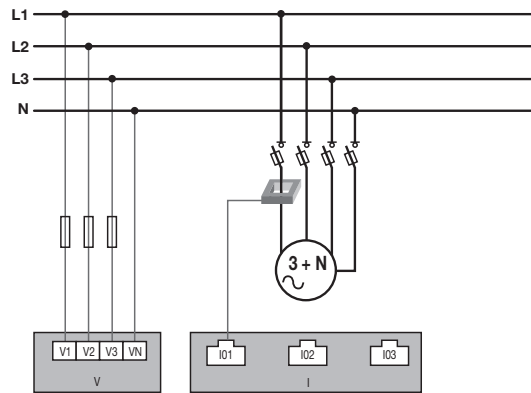

The 2CT solution reduces by 0.5% the accuracy of the phase for which the current is deduced by a vector calculation.

**Three-phase**

**3P - 1CT**

(1 balanced three-phase load)

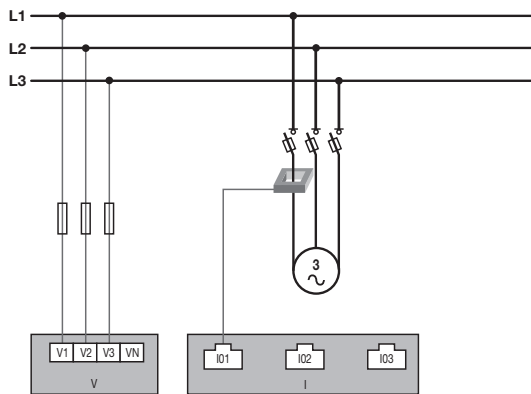

**Two-phase + Neutral**

**2P+N - 2CT**

(1 two-phase load + measured Neutral)

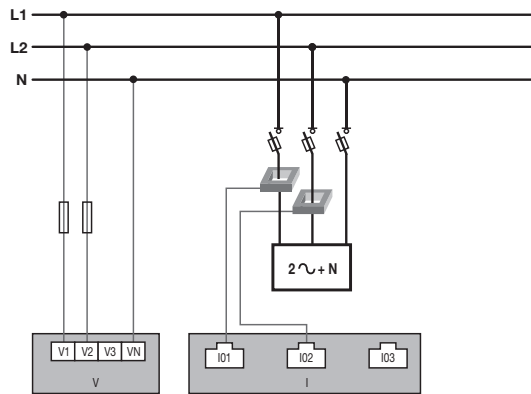

**Two-phase**

**2P - 1CT**

(1 two-phase load)

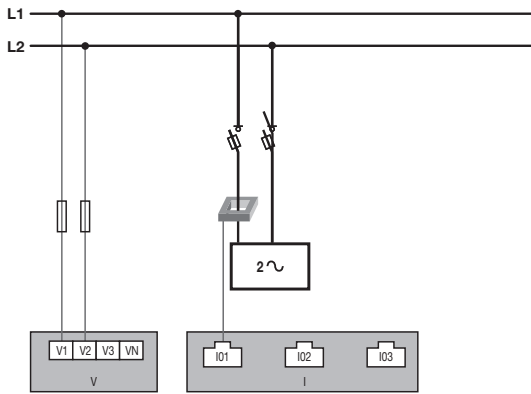

**Single-phase**

**1P+N - 1CT**

(1 single-phase load)

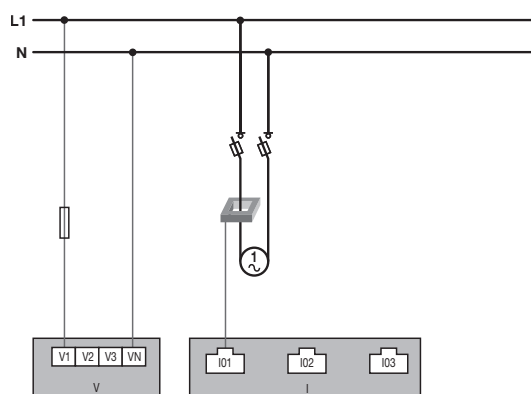

 Fuse: 0.5 A gG / 0.5 A class CC

# 7. COMMUNICATION

## 7.1. Modbus General information

The Modbus RTU available on the DIRIS A-40 communicates via an RS485 series link (2 or 3 wires) which is used to operate products from a PC or an API. In a standard configuration, an RS485 connection is used to connect 32 products to a PC or a controller over 1200 metres.

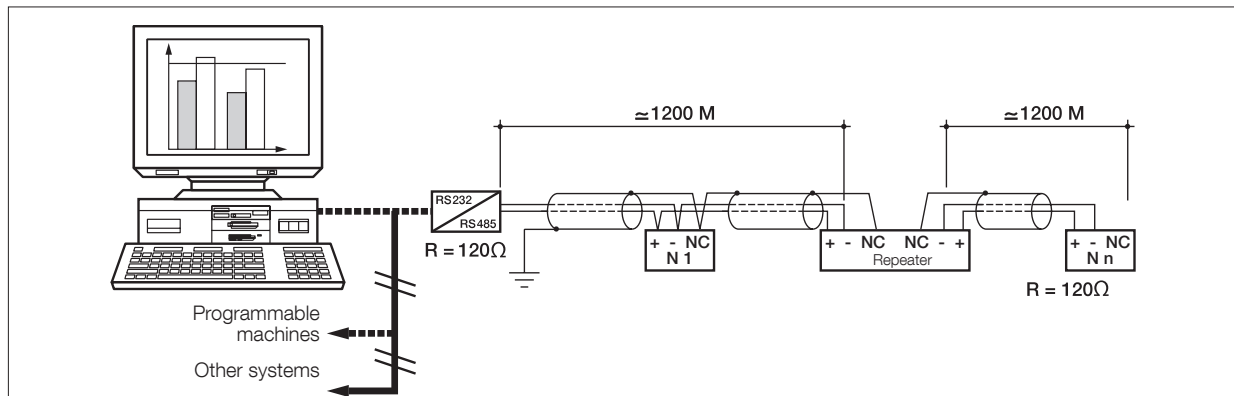
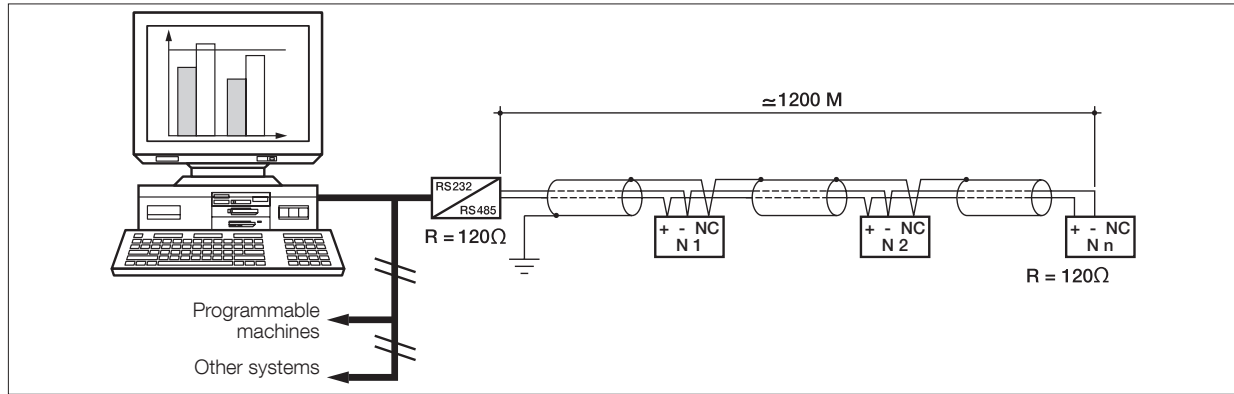

## 7.2. RS485 rules

A LIYCY shielded twisted pair must be used. We recommend using a shielded twisted pair with a general LIYCY-CY shielding in an environment where there is interference or in a very long network with a number of products.

If the distance of 1200 m is exceeded and/or the number of products is greater than 32, a repeater must be added to enable additional products to be connected.

A 120 Ohm resistor must be fixed at both ends of the connection.

## 7.3. Modbus and Profibus communication tables

The Modbus and Profibus communication tables and the associated explanations are available on the DIRIS A-40 documentation page on the website at the following address:

[www.socomec.com/en/documentation/diris-a40](http://www.socomec.com/en/documentation/diris-a40)



# 8. CONFIGURATION

The device can be configured directly from the DIRIS A-40 screen or with the Easy Config software. The following paragraphs describe configuration with Easy Config for different types of communication architecture and several types of connected SOCOMEC products.

## 8.1. Configuration using Easy Config

### 8.1.1. Connection modes

#### Configuration using Easy Config directly (USB)

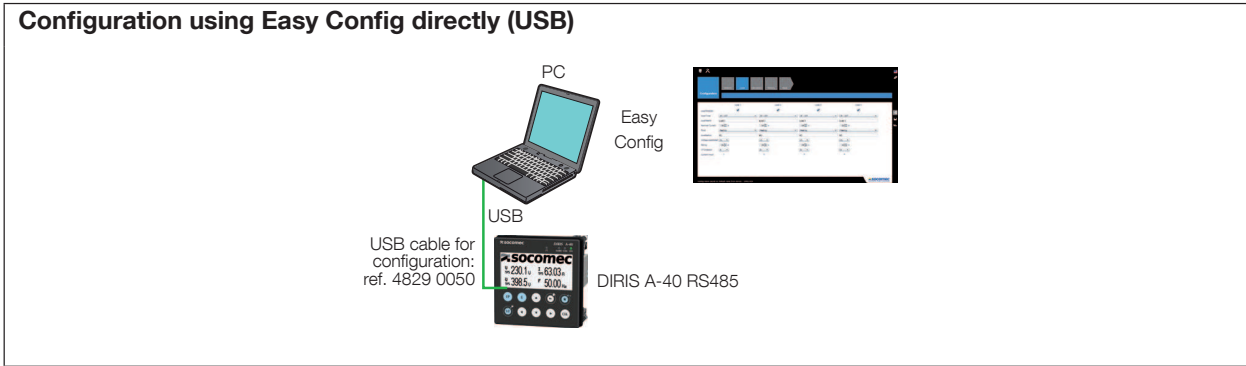

#### Configuration using Easy Config via a DIRIS G gateway (USB)

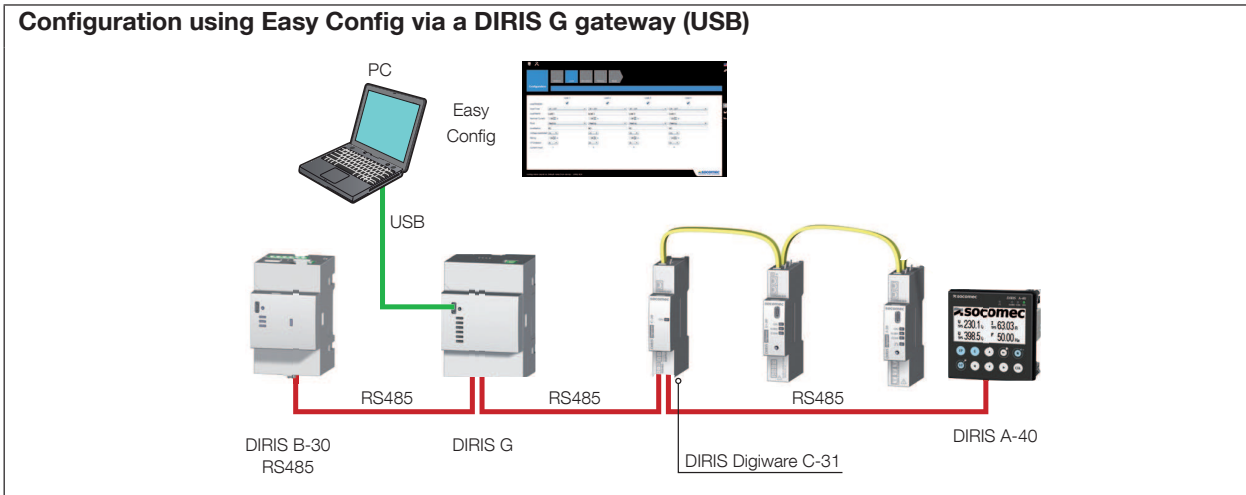

#### Configuration using Easy Config via a DIRIS G monitor (USB)

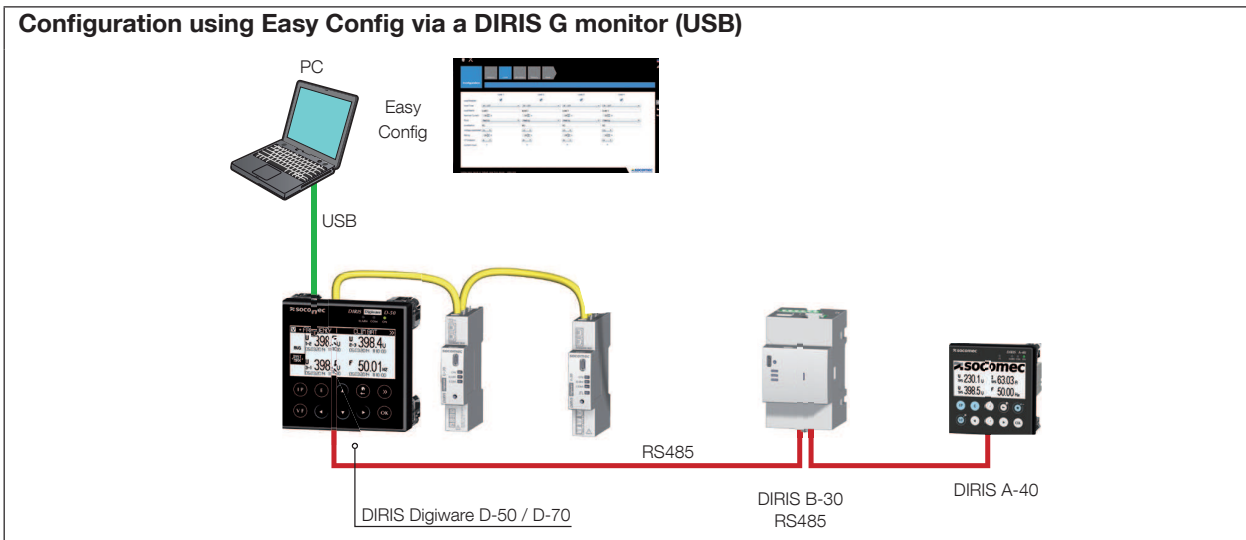

### Configuration using Easy Config via a DIRIS G gateway (Ethernet)

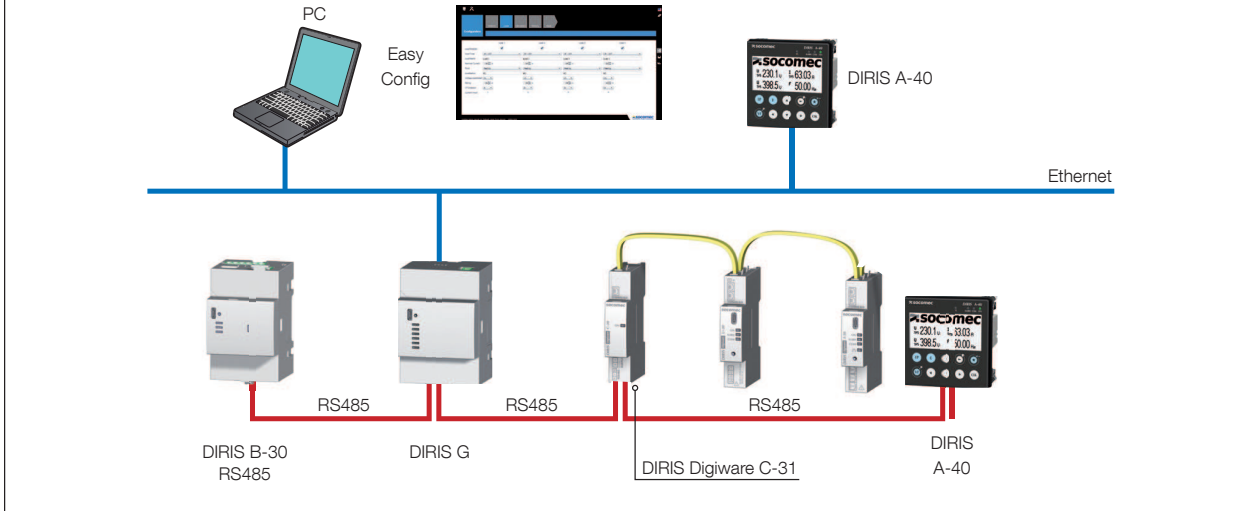

### Configuration using Easy Config via a DIRIS D-50 / D-70 monitor (Ethernet)

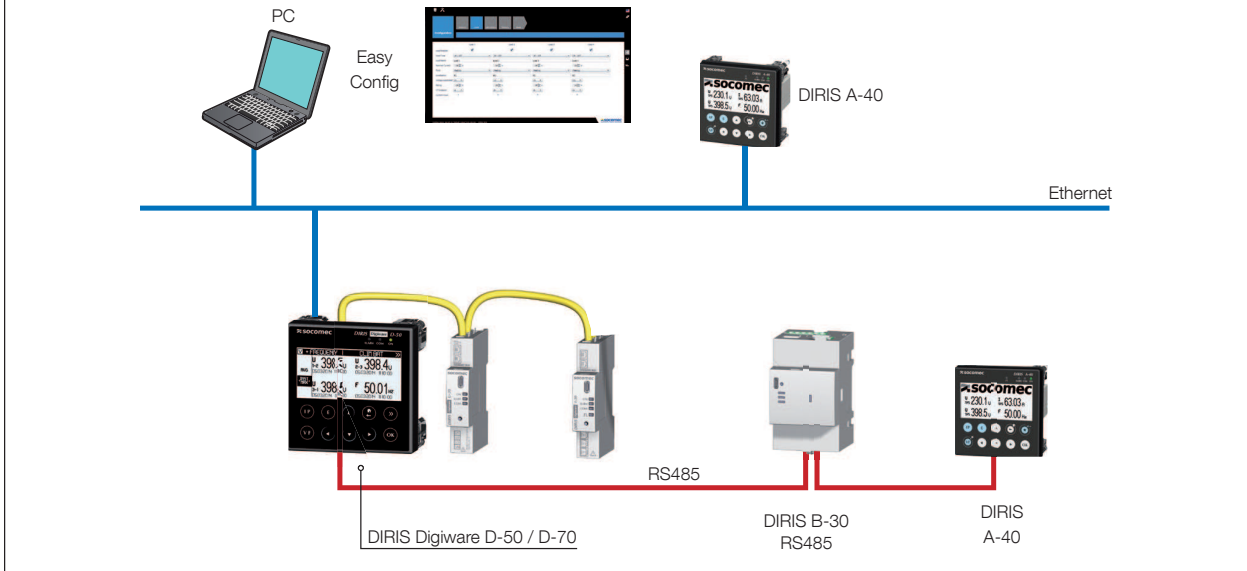

## 8.1.2. Using Easy Config

Easy Config is configuration software used to set product parameters easily and quickly. Parameters are set in successive steps:

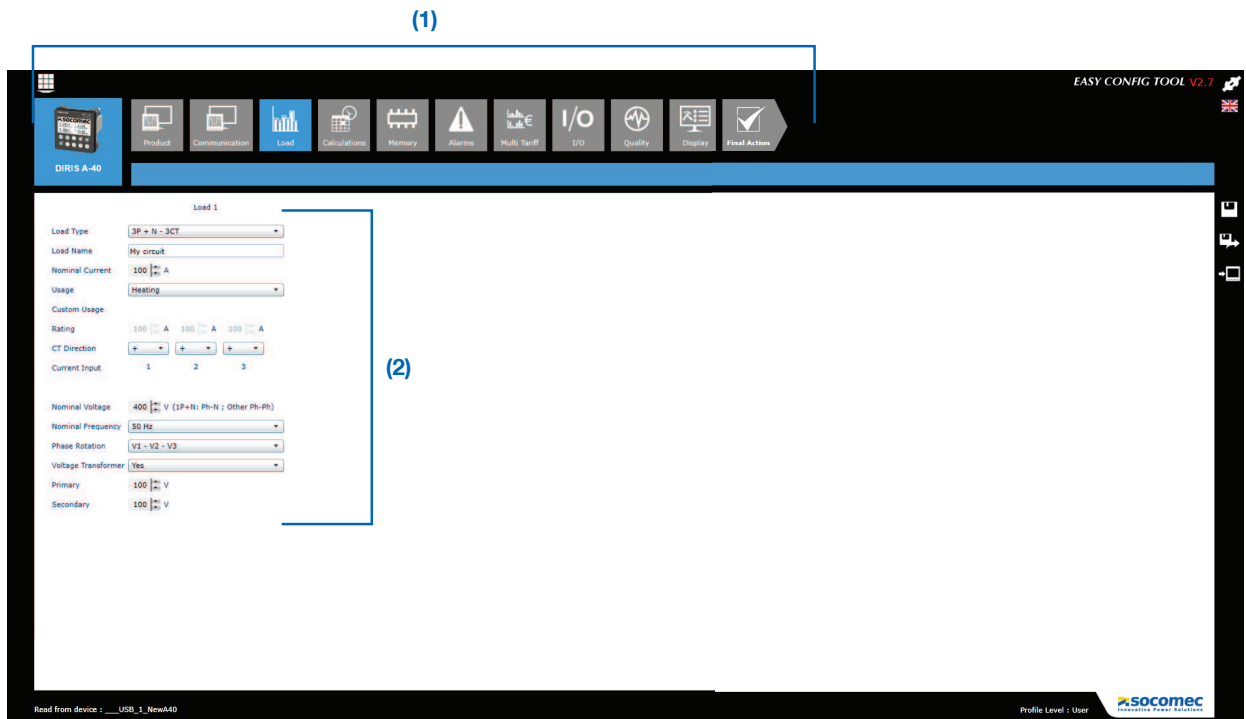

For each setting selected (1) a customised screen appears, depending on the connected product (2).

## Load configuration

The type of load can be accessed in the load configuration menu. The user can also define its nominal current, the name of the load, its usage and its location within the electrical installation. The user selects the nominal voltage, the network frequency, the direction of phase rotation and whether or not a voltage transformer is used.



## Calculation method

The integration period and the synchronisation methods of the different electric parameters are defined on this screen.

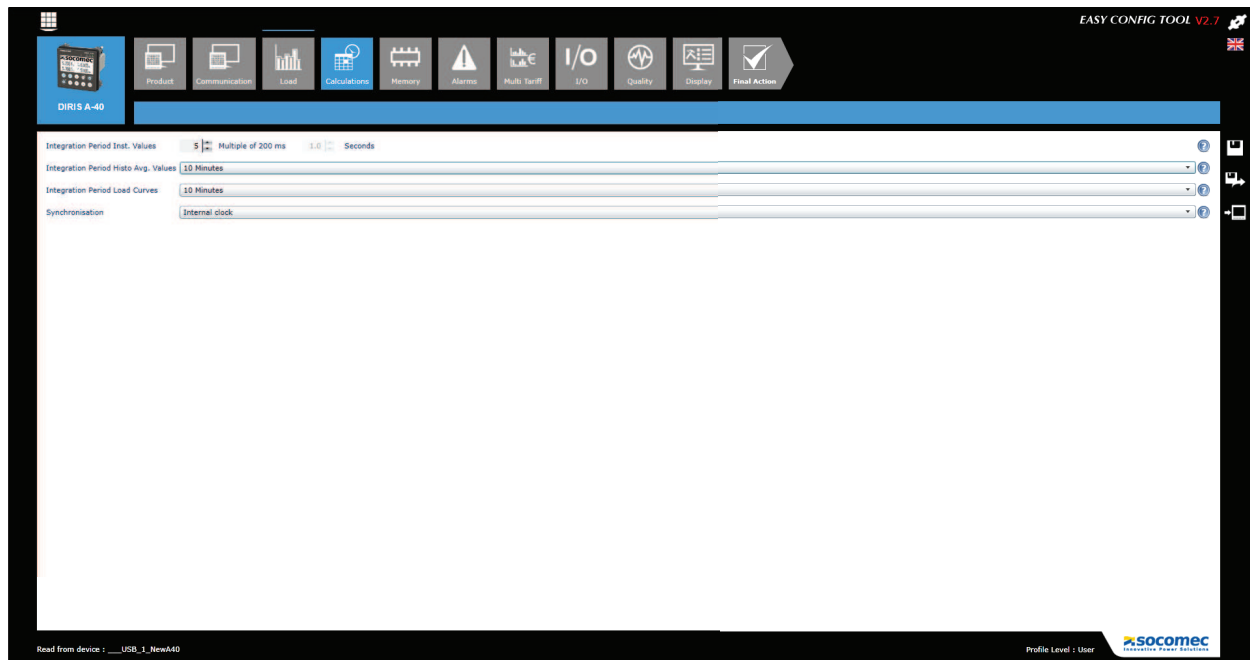

## Alarms

The type of alarm and the configuration are set in Easy Config, see section "10. ALARMS", for further details.

## Other settings

The other settings, such as Memory allocation, Multi-tariff, Inputs/Outputs, Quality events, Communication and other controls are also carried out with Easy Config.

Example of the screen for setting the Quality parameters of the electrical network:

The screenshot displays the 'EASY CONFIG TOOL v2.7' interface. The top navigation bar includes icons for Product, Communication, Load, Calculations, Memory, Alarms, Multi-tariff, I/O, Quality, Display, and Final Action. The main configuration area is titled 'Reference Voltage Fixed' and is divided into three sections: 'Voltage Dip', 'Voltage Swell', and 'Interruption'. Each section contains a 'Threshold' and 'Hysteresis' parameter, both set in percentage, with a question mark icon next to each. To the right of each section is a waveform icon representing the corresponding quality event. The bottom status bar shows 'Read from device : \_\_\_USB\_1\_New440' and 'Profile Level : User'.

Section	Threshold (%)	Hysteresis (%)
Voltage Dip	90	2
Voltage Swell	110	2
Interruption	5	2

## 8.2. Configuration from the display

### 8.2.1. Navigation



To access navigation, press "OK" to view the different menus available:

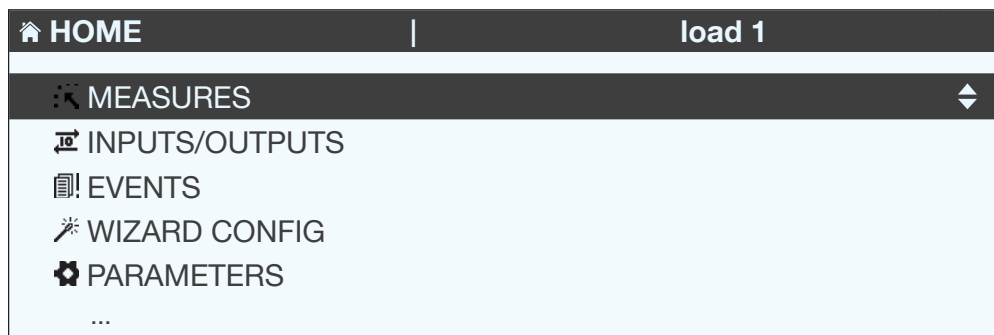

### 8.2.2. Description of the Wizard

The wizard allows very fast configuration of the main parameters of the DIRIS A-40:

The wizard is launched automatically at the first use and on demand for later uses. It is also possible to access the wizard by holding down the  button or via the menu on the screen using the "UP ARROW" and "DOWN ARROW" navigation buttons and confirming with "OK".

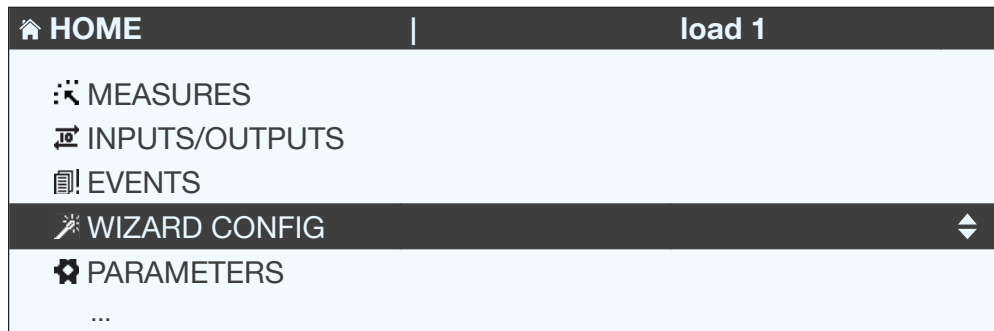

The wizard begins by choosing the language and allows configuration of the main parameters of the DIRIS A-40 by means of a series of screens:

- Date/time
- Load type
- Integration period
- Communication

The Wizard can be launched using 2 modes chosen by the user:

- "SMART CONFIG" mode: The type of electrical network and the load are detected automatically
- "MANUAL CONFIG" mode: the user himself configures the parameters of the electrical network and of the load



Note: the default access code for configuration is 100

### 8.2.3. Complete configuration

To access the complete configuration of the product and in particular the configuration of the alarms and of the additional parameters not covered by the Wizard, select the "PARAMETERS" menu:



Enter the password "100" using the arrow pad (4 arrow keys) and confirm with "OK":

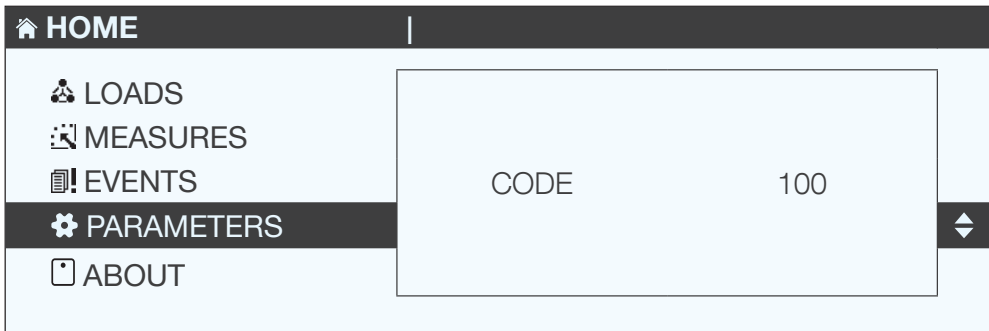

this gives access to the whole configuration of the DIRIS A-40:

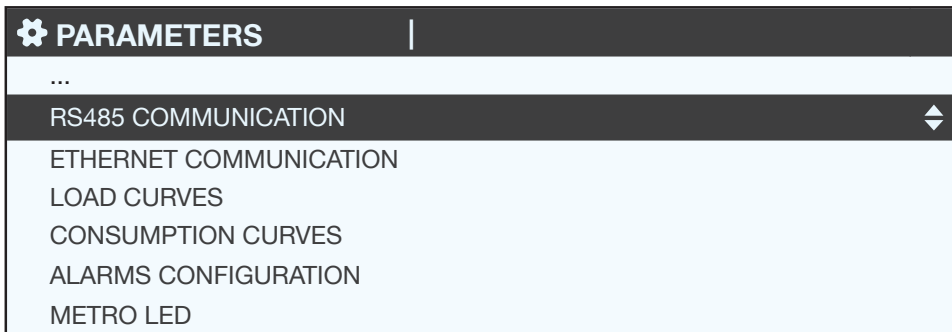

- DISPLAY: selection of the language, of the date and time and of the access code
- LOAD: selection of the type of load, of the nominal current, of rotation and of the voltage transformer
- SENSORS: selection of current direction
- CALCULATION: selection of the instantaneous and mean integration period
- INPUTS/OUTPUTS: settings of the inputs and outputs
- RS485 COMMUNICATION: settings of the RS485 communication parameters
- ETHERNET COMMUNICATION: settings of the Ethernet communication parameters
- PROFIBUS COMMUNICATION: settings of the Profibus communication parameters
- LOAD CURVES: settings of the integration period, synchronisation and selection of the calculated load curves
- CONSUMPTION CURVES: settings of the integration period and synchronisation of the consumption curves
- ALARMS CONFIGURATION: configuration of the alarms
- METRO LED: settings of the metrological LED parameters

## 8.3. Screen menu structure

### Menu structure

Measurements	Voltages	Phase-neutral voltage
		Phase-phase voltage
		Frequency
		Phase-neutral voltage unbalance
		THD Phase-neutral voltage
		THD Phase-neutral network
		Phase-neutral voltage harmonics
		Phase-neutral voltage crest factor
		Phase-phase voltage unbalance
		THD Phase-phase voltage
		Phase-phase voltage harmonics
		Phase-phase voltage crest factor
	Current	Current
		System Current
		Current Unbalance
		Current THD
Currents K factor		
Current Harmonics		
Current crest factor		
Power	Active power	
	Reactive power	
	Apparent power	
	Predictive power	
	Power factor	
	Cos Phi	
Energy	Tan Phi	
	Positive active energy	
	Negative active energy	
	Positive reactive energy	
	Negative reactive energy	
Positive/negative inductive/capacitive reactive energy		
Apparent energy		
Reset	Reset of all the min/max values	
Inputs/outputs	Digital inputs	Status
	Digital outputs	Status
Events	In progress	Alarms and Quality Events in progress
	History	Alarms and Quality Events ended and logged
Configuration Wizard		Wizard configuration screens
Parameters	Screen	Languages, Date format, Date, Time, Configuration access code
	Loads	Type of loads, Nominal values (V, I, f), Rotation, Voltage transformer
	Sensors	Current direction, Transformation ratio detected
	Integration period	Integration period instantaneous values and mean values
	Inputs/outputs	Name, Function (status, circuit breaker, pulse meter), Mode (N.O., N.C.)
	RS485 communication	Baudrate, stop bit, parity, address
	Ethernet communication	DHCP, IP Address, Template, Router
	Profibus communication	Address, exchanges with the master (parameters and diagnostic)
	Load curves	Integration period, Synchronisation, Choice of load curves to be saved (P+, P-, Q+, Q-, S)
	Consumption curves	Integration period, Synchronisation
	Alarm configuration	Alarm on instantaneous measurement, Alarm on digital input, System alarm
	Metrological LED	Choice of energy allocated to the LED (Ea+, Ea-, Er+, Er-, Es)
About	IP address	
	MAC address	
	Serial number	
	Software version	
	Reboot	

Note: the menus available depend on the product models.

# 9. USE

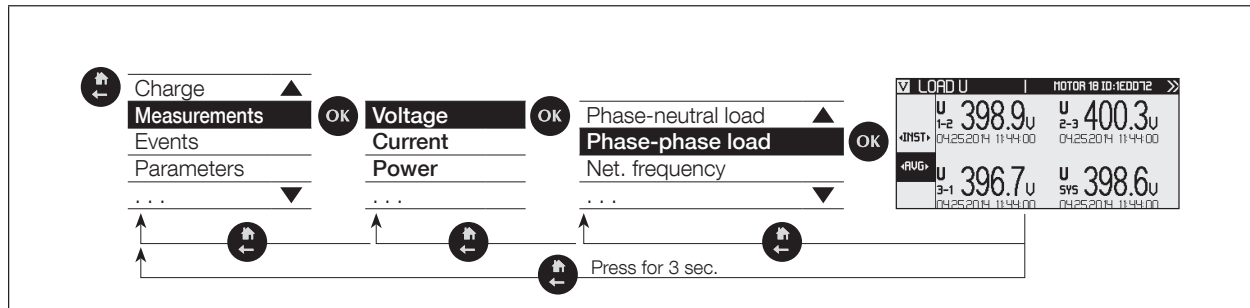

## 9.1. Browse

Browsing through the "MEASUREMENTS" menu allows access to all the measurements.



## 9.2. Shortcuts

The shortcut keys of the display "IP", "E", "VF" allow quick access to the current, power, energy, voltage or frequency measurements.

	<p>Shortcut keys for load measurements: current, active power, reactive power, apparent power, power factor, cosinus phi</p>
	<p>Shortcut keys for electrical network measurements: phase-to-neutral voltage, phase-to-phase voltage, frequency Shortcut keys for the Wizard by holding down</p>
	<p>Shortcut keys for active, reactive, apparent power counters (total and partial readings)</p>

## 9.3. Favourites

Use the Favourites function to save specific screens and to access them directly without browsing through the menus.

	<p>Use this to save favourite screens by holding down and then to view them with a short press Use this to remove favourite screens by holding down</p>
---	---

## 9.4. Screen display of measurements

The instantaneous and/or mean values are displayed depending on the types of measurement, shown as a numerical value or in graphic form.

# 10. ALARMS

## 10.1. Alarms upon events

Alarms can be generated when a threshold is exceeded for the electrical measurements, consumption, variations in level or change in input status. Also, combinations can be made on the alarms created.

Up to 50 alarms detected are saved and timestamped; an alarm can have 3 distinct statuses: Alarm active, Alarm completed, Alarm completed and acknowledged. Alarms can be acknowledged either automatically or by user action, as required.

Up to 8 alarms for an electrical measurement are configured per item of equipment and 9 for changes in status of a digital input.

The alarms are configured on the screen or via the Easy Config software.

### 10.1.1. Electrical parameters

- Alarm upon variation in the instantaneous or average value of an electrical value: Current, voltage, frequency, power, power factor, Cos phi, harmonic distortion rate
- Selection of the hysteresis and high/low threshold
- Setting a time delay at the start and end of the alarm
- For the associated total harmonic distortion, voltage and current three-phase values, an alarm may be generated if the condition is fulfilled on a combination of phases:
  - On a single-phase: Phase1, Phase2, Phase3
  - On all the phases simultaneously: Phase1 and Phase2 and Phase3
  - On one phase of the three phases: Phase1 or Phase2 or Phase3

Example of configuring an alarm on the current via Easy Config:

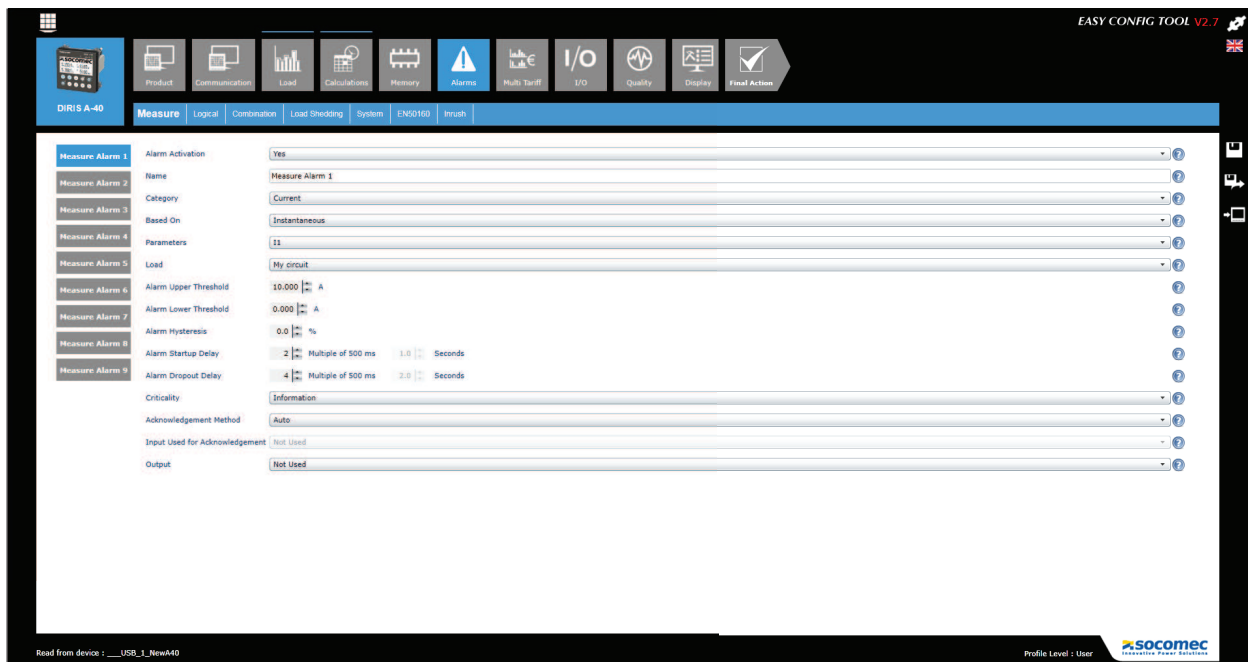

### 10.1.2. Voltage and current unbalance (in a three-phase network)

- Alarms on voltage unbalances: Unba, Unb
- Alarm upon current unbalance: Inba, Inb
- Selection of the hysteresis and high/low threshold
- Setting a time delay at the start and end of the alarm

### 10.1.3. EN 50160 voltage quality events

- Alarms on quality events for the voltage provided: voltage dips (Udip), temporary overvoltages (Uswl) and voltage outages (Uint).

### 10.1.4. Consumption

- Alarm on the energies: Ea+, Ea-, Er+, Er-, Eap
- Selection of a high threshold (excessive consumption)

### 10.1.5. Digital inputs

- Alarm upon change of status for a digital input
- Choice of a rising or falling edge
- Setting a time delay at the start and end of the alarm

Example of configuring an alarm on a digital input via Easy Config:

The screenshot shows the 'EASY CONFIG TOOL V2.7' interface for a DIRIS A-40 device. The 'Alarms' tab is selected, and the 'Logical' sub-tab is active. The configuration for 'Logical Alarm 1' is displayed as follows:

Alarm Activation	Yes
Name	Digital Alarm 1
Alarm Condition	Not Used
Alarm Startup Delay	0 Multiple of 500 ms 0.0 Seconds
Alarm Dropout Delay	0 Multiple of 500 ms 0.0 Seconds
Criticality	Information
Acknowledgement Method	Auto
Input Used for Acknowledgement	Not Used
Output	Not Used

### 10.1.6. Combination of alarms

- 4 boolean combinations (OR, AND) on the defined alarms (electrical values, energy, inputs, etc.)

The screenshot shows the 'EASY CONFIG TOOL V2.7' interface for a DIRIS A-40 device. The 'Alarms' tab is selected, and the 'Combination' sub-tab is active. The configuration for 'Combination Alarm 1' is displayed as follows:

Alarm Activation	Yes
Name	Combination Alarm 1
Alarm 1 Type	Measure
Alarm 1	Measure Alarm 1
Operation	AND
Alarm 2 Type	Measure
Alarm 2	Measure Alarm 2
Criticality	Information
Acknowledgement Method	Auto
Input Used for Acknowledgement	Not Used
Output	Not Used

## 10.2. System alarms

If an installation error is detected during setup, an alarm will be automatically generated.

### 10.2.1. Current/voltage compatibility

- Alarm upon connection error between the current and the voltage
- Requires a certain load level:  $0.6 < PF < 1$  and  $I > 2\% I_n$

### 10.2.2. Incorrect direction of rotation (three-phase network)

- Alarm upon identification of the incorrect direction of phase rotation (for example 3-2-1 instead of 1-2-3)

### 10.2.3. Faulty current sensor

- Alarm for detecting the absence of a current sensor

## 10.3. Setting up alarms

The installation alarms are automatically detected and alarms upon events are configured with the Easy Config software.

There are several ways of identifying the presence of an alarm:

### 10.3.1. ALARM LED on front

- Blinking: System Alarm
- Fixed: Alarm upon event (takes priority if there is a system alarm at the same time)

### 10.3.2. Activation of an output

- If an output is present on the product, it can be activated when an alarm is detected

### 10.3.3. Activation of an input

- If an input is present, the alarm can be acknowledged from this input. Acknowledgement of an alarm can only be taken into account if the alarm is complete

### 10.3.4. RS485 Modbus

- Information on the alarms with timestamping available via the RS485 communication bus
- Sends alarm acknowledgement

### 10.3.5. Screen and WEBVIEW

- Information on the alarms with timestamping
- Sends alarm acknowledgement



# 11. WEB SERVER

The Ethernet version of the DIRIS A-40, reference 4825 0501, has an embedded web server. This web server allows access to all the measurements of the electrical parameters and of the energy measured by the DIRIS A-40.

The default IP address for accessing the web server is the following: 192.168.0.4

Below are some examples of the web server screen:

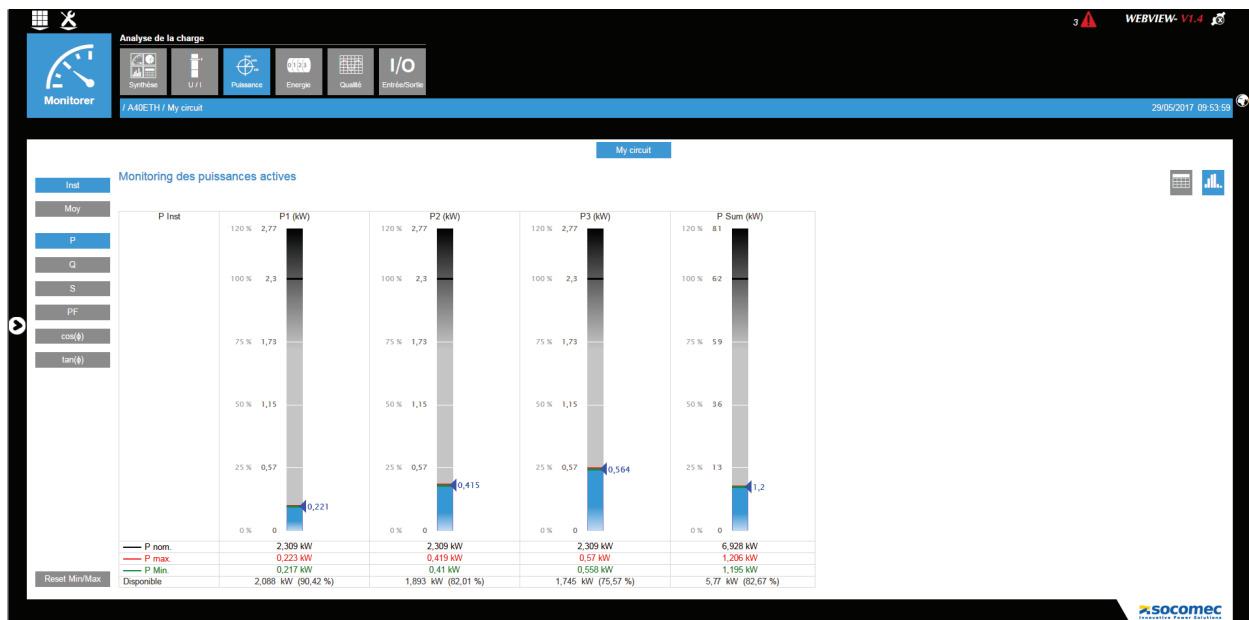
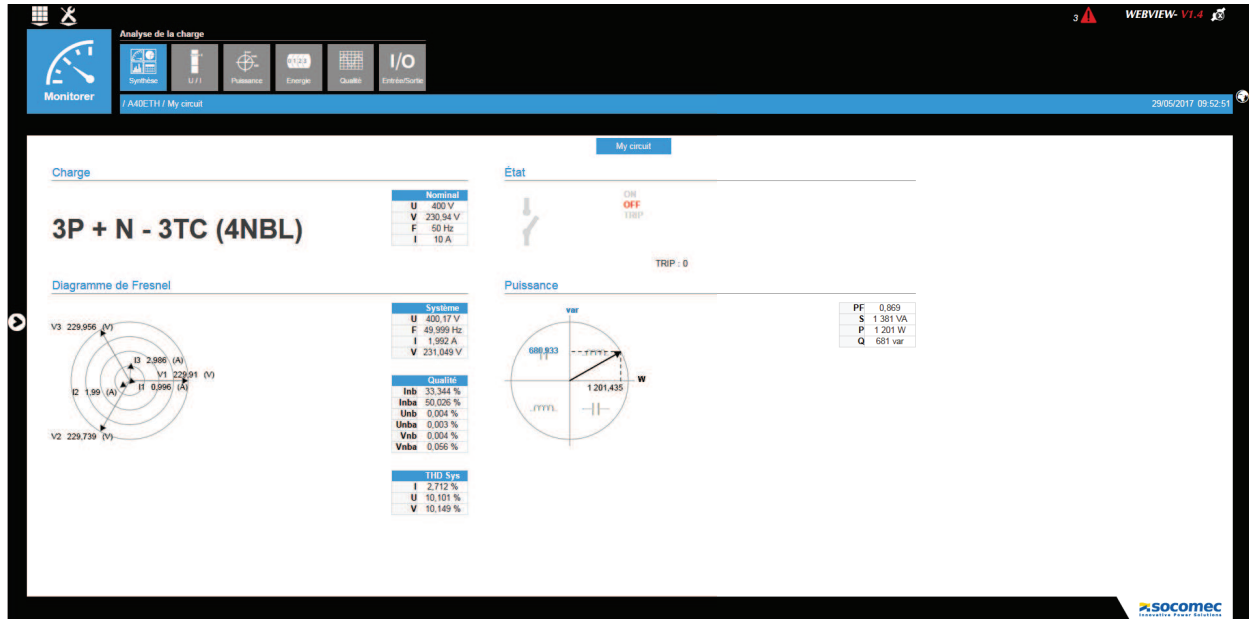

# 12. CHARACTERISTICS

## 12.1. DIRIS A-40 characteristics

### 12.1.1. Mechanical features

Casing type	Fitted on a door with format 96x96
Protection degree	IP52 front panel / IP20 rear panel
Type of screen	Capacitive touch-screen technology, 10 keys Screen resolution: 350 x 160 pixels
Weight	ref 4825 0500: 326 g ref 4825 0501: 341 g ref 4825 0502: 349 g

### 12.1.2. Electrical specifications

Auxiliary power supply			
Voltage	110-277VAC L/N 277-400VAC L/L' 120-300 VDC Overvoltage category III		
Frequency	50-60 Hz		
Power consumption	4825 0500: 110-277VAC L/N: 4VA 277-400VAC L/L': 5VA 120-300VDC: 1.5VA	4825 0501: 110-277VAC L/N: 6VA 277-400VAC L/L': 8VA 120-300VDC: 2.5VA	4825 0502: 110-277VAC L/N: 6VA 277-400VAC L/L': 8VA 120-300VDC: 2.5VA
Connection	Removable spring-cage terminal block, 2 positions, 0.5 - 2.5 mm <sup>2</sup> solid cable or 0.25 - 1.5 mm <sup>2</sup> stranded cable with end piece		

### 12.1.3. Measuring characteristics

Measurement accuracy	
Accuracy	According to IEC 61557-12 PMD DD classification in association with dedicated sensors (TE, TR, TF)
Energy and power measurement	
Active energy and active power accuracy	Class 0.2 DIRIS A-40 only Class 0.5 with TE, iTR or TF sensors Class 1 with TR sensors
Accuracy of reactive energy	Class 2 with TE, TR, iTR or TF sensors
Power factor measurement	
Accuracy	Class 0.5 with TE, iTR or TF sensors Class 1 with TR sensors
Voltage measurement	
Characteristics of the network measured	50-300 VAC (L/N) - 87-520 VAC (L/L') - CAT III
Frequency range	45 to 65Hz
Frequency accuracy	Class 0.02
Network type	Single-phase/ Two-phase / Two-phase with neutral / Three-phase / Three-phase with neutral
Measurement by voltage transformer	Primary: 400 000 VAC Secondary: 60, 100, 110, 173, 190 VAC
Input consumption	≤ 0,1 VA
Accuracy of voltage measurement	Class 0.2
Connection	Removable spring-cage terminal block, 4 positions, 0.5 - 2.5 mm <sup>2</sup> solid cable or 0.25 - 1.5 mm <sup>2</sup> stranded cable with end piece

<b>Current measurement</b>	
Number of current inputs	3
Associated current sensors	Solid-core TE, split-core TR, iTR flexible TF current sensors
Accuracy	Class 0.2 DIRIS A-40 only Class 0.5 with TE, iTR or TF sensors Class 1 with TR sensors
Connection	Specific Socomec cable with RJ12 connectors

#### 12.1.4. Input/output characteristics

<b>Inputs</b>	
Number	3
Type / Power supply	Optocoupler with internal (12 VDC ± 10%) or external (12-24 VDC± 20%) polarisation
Input function	Logical state, pulse meter, circuit breaker status or synchronisation pulse (input 1)
Connection	Removable screw terminal block, 5 positions, stranded or solid 0.14 - 1.5 mm <sup>2</sup> cable
<b>Outputs</b>	
Number	2
Type	Optocoupler 30 Vd.c. max 20mA max - SELV
Output function	Configurable alarm signal (current, power, etc.) when threshold is exceeded or remote controlled status
Connection	Removable screw terminal block, 4 positions, stranded or solid 0.14 - 1.5 mm <sup>2</sup> cable

#### 12.1.5. Communication specifications

<b>RS485</b>	
Product	DIRIS A-40
Link	RS485
Connection type	2 to 3 half duplex wires - SELV
Protocol	Modbus RTU
Baudrate	9600 to 115200 bauds
Function	Data configuration and reading
Connection	Removable screw terminal block, 3 positions, stranded or solid 0.14 - 1.5 mm <sup>2</sup> cable
<b>ETHERNET</b>	
Product	DIRIS A-40 ref. 4825 0501
Link	Ethernet
Connection type	Ethernet 10/100 Base-T - SELV
Protocol	Modbus TCP (port 502), Modbus RTU over TCP (port 503) BACnet, SNMP, SMTP, FTP
SNTP protocol	Updates from an NTP server.
SMTP protocol	Sends a mail in case of an alarm
FTP protocol	Saves the measurement files on an FTP server
Functions	Data configuration and reading
Connection	RJ45 port
<b>PROFIBUS</b>	
Product	DIRIS A-40 ref. 4825 0502
Link	RS485 - SELV
Protocol	PROFIBUS DPV1

Functions	PROFIBUS communication
Connection	SubD9 Connector
<b>USB</b>	
Connection	USB 2
Protocol	Modbus RTU on USB
Function	Configuration
Connection	Type B micro USB connector

### 12.1.6. Environmental specifications

IP	IP52 front IP20 rear
Ambient operating temperature	-10 - +70°C (IEC 60068-2-1 / IEC 60068-2-2)
Storage temperature	-25 - +85°C (IEC 60068-2-1 / IEC 60068-2-2)
Operating humidity	+70°C / 97% HR (IEC 60068-2-30)
Operating altitude	< 2,000 m
Vibration	0.35 mm, 25 Hz, 20 min/axe (IEC 61557-12)
PEP ecopassport - ISO 14025	SOCO-000007-V01.01-EN
Impact resistance	Front panel: 5J - casing: 1J (IEC 61010-1 Ed 3.0)

### 12.1.7. Electromagnetic compatibility

Immunity to electrostatic discharges on contact	IEC 61000-4,-2	LEVEL III	Criterion A
Immunity to electrostatic discharges in the air	IEC 61000-4,-2	LEVEL III	Criterion A
Immunity to radiated radio-frequency fields	IEC 61000-4,-3	80-1000MHz LEVEL III 1400-2700MHz LEVEL III	Criterion A
Immunity to electrical fast transients/bursts	IEC 61000-4,-4	Power supply LEVEL III Voltage measurement LEVEL IV Current inputs LEVEL III RS485 LEVEL III Ethernet LEVEL III Profibus LEVEL III E/S LEVEL III Earth LEVEL III	Criterion B Criterion B Criterion A Criterion A Criterion A Criterion A Criterion A Criterion A
Immunity to impulse waves	IEC 61000-4,-5	Power supply LEVEL III Voltage measurement LEVEL III RS485 LEVEL II Ethernet LEVEL II Profibus LEVEL II E/S LEVEL II	Criterion A Criterion A Criterion A Criterion B Criterion A Criterion A
Immunity to conducted disturbances, induced by radio-frequency fields	IEC 61000-4,-6	Power supply LEVEL III Voltage measurement LEVEL III Current inputs LEVEL III RS485 LEVEL III Ethernet LEVEL II Profibus LEVEL III E/S LEVEL III Earth LEVEL III	Criterion A Criterion A Criterion A Criterion A Criterion A Criterion A Criterion A Criterion A
Immunity to power frequency magnetic fields	IEC 61000-4,-8	400A/m	Criterion A
Immunity to voltage dips, short interruptions and voltage variations	IEC 61000-4,-11	Voltage dip: 0% for 1 cycle 40% for 10/12 cycles 70% for 25/30 cycles Short interruption: 0% for 250/300 cycles	Criterion A Criterion A Criterion A Criterion C
Radiated emissions	CISPR11	Gr:1 - CLASS A	N/A
Conducted emissions	CISPR11	Gr:1 - CLASS B	N/A

Electromagnetic environment	Industrial
-----------------------------	------------

### 12.1.8. Safety

Safety	Compliant with Low Voltage Directive: 2014/35/EU of 26 February 2014 (IEC EN61010-1 & IEC EN61010-2-030) Compliant with Electromagnetic Compatibility Directive: 2014/30/EU of 26 February 2014
Insulation	Installation category III (300VAC Ph/N), degree of pollution 2
UL	UL61010-1 & UL61010-2-030  UL installation: DIRIS A-40 and current sensors have to be enclosed inside an NRTL certified electrical/fire enclosure, Listed Industrial Control Equipment, or similar equipment.

### 12.1.9. Service life

MTTF (mean time to failure)	> 100 years
-----------------------------	-------------

## 12.2. TE, TR / iTR and TF sensor characteristics

TE - closed sensor TE-18 to TE-55						
Model	TE-18	TE-18	TE-25	TE-35	TE-45	TE-55
Nominal current range $I_n$ (A)	5 - 20	25 - 63	40 - 160	63 - 250	160 - 630	400 - 1000 <sup>(1)</sup>
Max. current (A)	24	75.6	192	300	756	1200
Weight (g)	24	24	69	89	140	187
Max. voltage	300 V					
Rated withstand voltage	3 kV					
Frequency	50/60 Hz					
Intermittent overload	10x $I_n$ in 1 second					
Measurement category	CAT III					
Protection degree	IP30 / IK06					
Operating temperature	-10 - +70°C					
Storage temperature	-25 - +85°C					
Relative humidity	95% RH without condensation					
Altitude	< 2,000 m					
PEP ecopassport - ISO 14025	TE sensors: SOCO-2014-03-v1-fr, SOCO-2014-03-v1-en					
UL	UL 61010					
Connection	SOCOMEK RJ12 cable, straight, twisted pair, unshielded, 600 V -10 / +70 °C - SELV					
<i>(1) &gt; 1000 A with adapter TC 5 A.</i>						
TE - closed sensor TE-90						
Model	TE-90					
Nominal current range $I_n$	600 A - 2000 A					
Max. current	2400 A					
Weight	163g (118g without clamps)					
Max. voltage	600 V					
Rated withstand voltage	3.6 kV AC 1 min					
Frequency	50/60 Hz					
Intermittent overload	40x $I_n$ in 0.5 sec					
Measurement category	CAT III					
Protection degree	IP30					
Operating temperature	-10 - +70°C					
Storage temperature	-25 - +85°C					
Relative humidity	95% RH without condensation					
Altitude	< 2,000 m					
Connection	SOCOMEK RJ12 cable, straight, twisted pair, unshielded, 600 V -10 / +70 °C - SELV					

<b>TR / iTR - Split-core sensor</b>					
Model	<b>TR-10 / iTR-10</b>	<b>TR-14 / iTR-14</b>	<b>TR-21 / iTR-21</b>	<b>TR-32 / iTR-32</b>	
Nominal current range I <sub>n</sub> (A)	26 - 63	40 - 160	63 - 250	160 - 600	
Max. current (A)	75.6	192	300	720	
Weight (g)	74	117	211	311	
Max. voltage	300 V				
Voltage detection	iTR				
Rated withstand voltage	3 kV				
Frequency	50/60 Hz				
Intermittent overload	10x I <sub>n</sub> in 1 second				
Measurement category	CAT III				
Protection degree	IP20 / IK06				
Operating temperature	-10 - +55°C				
Storage temperature	-25 - +85°C				
Relative humidity	95% RH without condensation				
Altitude	< 2,000 m				
PEP ecopassport - ISO 14025	SOCO-00007-V01.01-EN				
UL	UL 61010				
Connection	SOCOMEK RJ12 cable, straight, twisted pair, unshielded, 600 V -10 / +70 °C - SELV				
<b>TF - Flexible current sensor</b>					
Model	<b>TF-55</b>		<b>TF-120</b>		<b>TF-300</b>
Nominal current range I <sub>n</sub> (A)	150 - 600		500 - 2000		1600 - 6000
Weight (g)	114		142		220
Max. voltage	600 V				
Rated withstand voltage	3.6 kV				
Frequency	50 / 60 Hz				
Intermittent overload	10x I <sub>n</sub> in 1 second				
Measurement category	CAT III				
Protection degree	IP30 / IK07				
Operating temperature	-10 - +70°C				
Storage temperature	-25 - +75°C				
Relative humidity	95% RH without condensation				
Altitude	< 2,000 m				
UL	UL 61010				
Connection	SOCOMEK RJ12 cable, straight, twisted pair, unshielded, 600 V -10 / +70 °C - SELV				

# 13. PERFORMANCE CLASSES

Performance classes are drawn up in compliance with IEC 61557-12 Edition 1 (08/2007)

Classification of the DIRIS A-40	DD in combination with dedicated sensors (TE, TR, TF)
Temperature	K55
Overall operating performance class for active power or active energy	0.5 in combination with TE, iTR or TF solid-core sensors 1 in combination with TR split-core sensors

## 13.1. Specification of the characteristics

Symbol	Function	Overall operating performance class DIRIS A-40 + dedicated sensors* (TE, TR, iTR, TF) in compliance with IEC 61557-12	Measurement range
Pa	Total active power	0.2% DIRIS A-40 only 0.5 with TE, iTR or TF sensors 1 with TR sensors	10% - 120% In 2% - 120% In 2% - 120% In
$Q_A, Q_V$	Total reactive power (arithmetic, vectorial)	1 with TE, TR or TF sensors	5% - 120% In
$S_A, S_V$	Total apparent power (arithmetic, vectorial)	0.5 with TE, iTR or TF sensors 1 with TR sensors	10% - 120% In
Ea	Total active energy	0.2% DIRIS A-40 only 0.5 with TE, iTR or TF sensors 1 with TR sensors	10% - 120% In 2% - 120% In 2% - 120% In
$Er_A, Er_V$	Total reactive energy (arithmetic, vectorial)	2 with TE, TR, iTR or TF sensors	5% - 120% In
$Eap_A, Eap_V$	Total apparent energy (arithmetic, vectorial)	0.5 with TE, iTR or TF sensors 1 with TR sensors	10% - 120% In
f	Frequency	0.02	45 - 65 Hz
I	Phase current	0.2 DIRIS A-40 only 0.5 with TE, iTR or TF sensors 1 with TR sensors	5% - 120% In 10% - 120% In 10% - 120% In
INc	Calculated neutral current	1 with TE, iTR or TF sensors 2 with TR sensors	10% - 120% In
U	Voltage (Lp-Lg or Lp-N)	0.2	50 - 300 VAC Ph/N
$PF_A, PF_V$	Power factor (arithmetic, vectorial)	0.5 with TE, iTR or TF sensors 1 with TR sensors	0.5 lagging to 0.8 leading
Pst, Plt	Flicker (short-term, long-term)	-	-
Udip	Voltage dip (Lp-Lg or Lp-N)	0.5	-
Uswl	Voltage swell (Lp-Lg or Lp-N)	0.5	-
Uint	Voltage interruption (Lp-Lg or Lp-N)	0.2	-
Unba	Voltage amplitude unbalance (Lp-N)	0.5	-
Unb	Voltage phase and amplitude unbalance (Lp-Lg or Lp-N)	0.2	-
THDu, THD-Ru	Total harmonic distortion rate of the voltage (relative to the fundamental, relative to the efficient value)	1	Orders 1 to 63
Uh	Voltage harmonics	1	-
THDi, THD-Ri	Total harmonic distortion rate of the current (relative to the fundamental, relative to the efficient value)	1 with TE, TR, iTR or TF sensors	Orders 1 to 63
Ih	Current harmonics	1 with TE, TR, iTR or TF sensors	-
Msv	Centralised remote control signals	-	-

\*With SOCOMEC connection cables.



## 13.2. Evaluation of the power supply quality

Symbol	Function	Overall operating performance class DIRIS A-40 + dedicated sensors (TE, TR, iTR, TF) in compliance with IEC 61557-12	Measurement range
f	Frequency	0.02	45 - 65 Hz
I	Phase current	0.2 DIRIS A-40 only 0.5 with TE, iTR or TF sensors 1 with TRsensors	5% - 120% In 10% - 120% In 10% - 120% In
INc	Calculated neutral current	1 with TE, iTR or TF sensors 2 with TRsensors	10% - 120% In
U	Voltage (Lp-Lg or Lp-N)	0.2	50 - 300 VAC Ph/N
Pst, Plt	Flicker (short-term, long-term)	-	-
Udip	Voltage dip (Lp-Lg or Lp-N)	0.5	-
Uswl	Voltage swell (Lp-Lg or Lp-N)	0.5	-
Uint	Voltage interruption (Lp-Lg or Lp-N)	0.2	-
Unba	Voltage amplitude unbalance (Lp-N)	0.5	-
Unb	Voltage phase and amplitude unbalance (Lp-Lg or Lp-N)	0.2	-
Uh	Voltage harmonics	1	-
Ih	Current harmonics	1 with TE, TR, iTR or TF sensors	-
Msv	Centralised remote control signals	-	-

---

CORPORATE HQ CONTACT:  
SOCOMECSAS  
1-4 RUE DE WESTHOUSE  
67235 BENFELD, FRANCE

---

[www.socomec.com](http://www.socomec.com)



545 802 A - EN - 08/17

 **socomec**  
Innovative Power Solutions